

UK PAT NO:GB2362428
 UK PAT NO:GB2361753
 UK PAT NO:GB2352475
 USA PAT NO:US6708377
 USA PAT NO:US7384078
 EUR PAT NO: EP1230505
 AUSTRALIAN PAT NO:AU774546
 INDIA PAT NO:IN199286

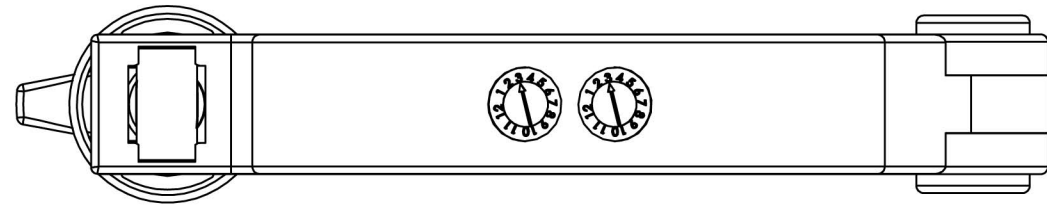

CLOCK

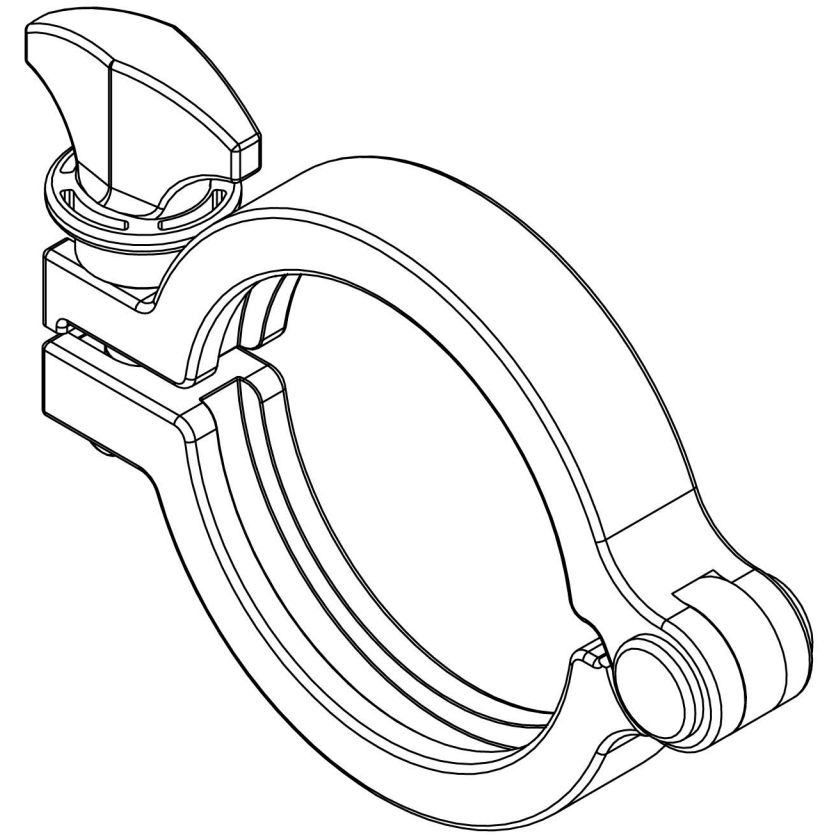
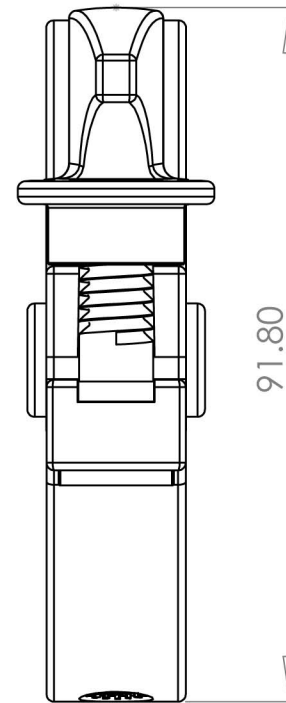
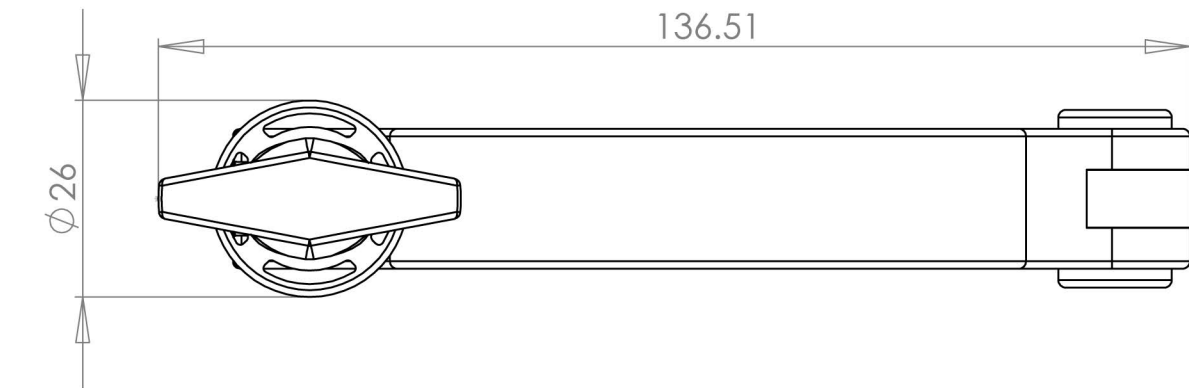
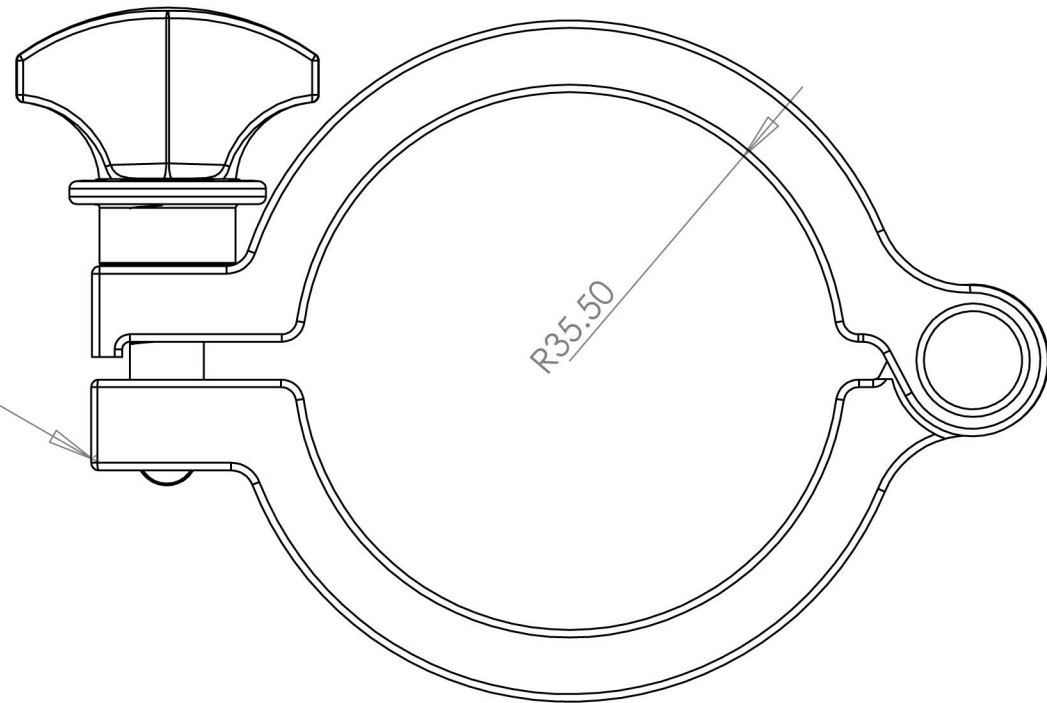

copyright ©
 This drawing and its associated design is the property of Bio-pure technology Ltd & may not be copied or used for any purpose other than that for which it was supplied, without the express written authority of bio pure technology Ltd.



BioPure Technology Ltd,
 Unit M1, Hazleton Interchange,
 Lakesmere Road, Horndean, PO8 9JU.
 Tel: +44 (0) 2392 499000
 Fax: +44 (0) 2392 499001
 Email: sales@biopuretech.com
 Web: www.biopuretech.com

ITEM	QTY	PART ID	MATERIAL	FILE NAME: CLAMP 2.5 ASSY
UNLESS OTHERWISE STATED DIMENSIONS IN mm TOL = +/- 0.1mm ANGLES = +/- 0.1 DEG	SIZE A4	ISSUE: C SHEET: 1	FINISH: WHITE WT 192	TITLE: BIO-CLAMP NG250WHT
			MATERIAL:GLASS REINFORCED NYLON	DWG NO: NG250WHT
			DEBUR AND BREAK SHARP EDGES	WEIGHT: DENSITY:
			SCALE NTS	