

Bredel 10-20 Operating Manual

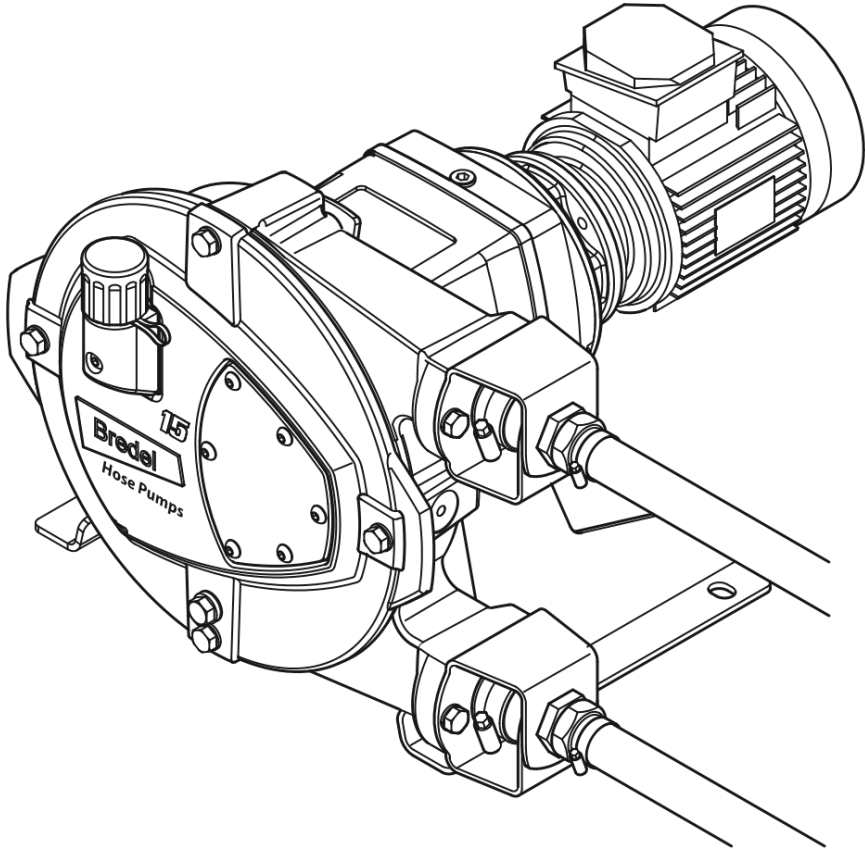

**ISO
9001**
Quality
Management

**ISO
14001**
Environmental
Management

**OHSAS
18001**
Occupational
Health & Safety
Management

Contents

1 General	6
1.1 How to use this manual	6
1.2 Original instructions	6
1.3 Other supplied documentation	6
1.4 Service and support	6
1.5 Environment and disposal of waste	7
2 Safety	8
2.1 Symbols	8
2.2 Intended use	8
2.3 Use in potentially explosive atmospheres	9
2.4 NSF/ANSI 61 certification	9
2.5 Responsibility	9
2.6 Qualification of the user	10
2.7 Regulations and instructions	10
3 Warranty conditions	11
4 Description	12
4.1 Identification of the product	12
4.2 Construction of the pump	16
4.3 Operation of the pump	17
4.4 Pump installation positions	18
4.5 Hose	19
4.6 Gearbox	20
4.7 Electric motor	21
4.8 Frequency controller	21
4.9 Available options	21
5 Installation	22
5.1 Unpacking and inspection	22
5.2 Installation conditions	22
Set-up	23
5.3 Lifting and moving the pump	25
5.4 Placing the pump	26

6 Commissioning	28
6.1 Preparations	28
6.2 Commissioning	29
7 Operation	30
7.1 Temperature	30
7.2 Power rating	30
7.3 Performance graphs	30
7.4 Dry running	33
7.5 Hose failure	33
7.6 Fluid leakage	35
8 Maintenance	36
8.1 General	36
8.2 Maintenance and periodic inspections	36
8.3 Additional maintenance in potentially explosive environments	38
8.4 Cleaning the hose	38
8.5 Changing lubricant	39
8.6 Changing the hose	40
8.7 Exchanging replacement parts	44
8.8 Fitting the hose	49
8.9 Fitting options	52
9 Storage	55
9.1 Hose pump	55
9.2 Hose	55
9.3 Lubricant	55
10 Troubleshooting	56
11 Specifications	61
11.1 Pumphead	61
11.2 Gearbox	67
11.3 Electric motor	67
11.4 Bredel Variable Frequency Drive (VFD) (optional)	68
11.5 Parts list	69
12 Safety form	91

Copyright

© 2024 Watson-Marlow Bredel B.V. All rights reserved.

The information provided herein may not be reproduced and/or published in any form, by print, photoprint, microfilm or any other means whatsoever (electronically or mechanically) without the prior written authorisation of Watson-Marlow Bredel B.V..

Names, trade names, brands, etc. used by Watson-Marlow Bredel B.V. may not, as per the legislation concerning the protection of trade names, be considered as available.

Disclaimers

The information contained in this document is believed to be correct but Watson-Marlow Bredel B.V. accepts no liability for any errors it contains and reserves the right to alter specifications without notice.

The information provided can be changed without prior notification. Watson-Marlow Bredel B.V. or one of its representatives cannot be held liable for possible damage resulting from use of this manual. This is an extensive limitation of the liability which applies to all damage, inclusive of (without limitation) compensating, direct, indirect or consequential damage, loss of data, income or profit, loss or damage to possessions and claims of third parties.

QR code



English	To get the translation of the manual in your language, scan the QR code.
Nederlands	Scan de QR code om de vertaling van de handleiding in uw taal te krijgen.
Deutsch	Um die Übersetzung des Handbuchs in Ihrer Sprache zu erhalten, scannen Sie den QR-Code.
Português	Para obter a tradução do manual no seu idioma, faça a leitura do código QR.
Español	Para obtener la traducción del manual en su idioma, escanee el código QR.
Français	Pour accéder à la traduction du manuel dans votre langue, scannez le code QR.
Italiano	Per ottenere la traduzione del manuale nella propria lingua, acquisire il codice QR.
Česky	Chcete-li získat překlad příručky ve vašem jazyce, naskenujte QR kód.
Magyar	Ha a kézikönyvet saját nyelvén szeretné, akkor használja a lemezt vagy szkennelje be a QR kódot.
Polski	Aby pobrać instrukcję przetłumaczoną na Państwa język, płyty lub zeskanować kod QR.
Русский	Для получения руководства на своем языке установите диск или отсканируйте QR-код.
Dansk	For at se en oversættelse af vejledningen på dit sprog, scanne QR-koden.
Suomi	Saadaksesi käyttöoppaan omalla kielelläsi, skannaa QR-koodi.

Norsk F or å lese håndboken oversatt til ditt eget språk, scan QRkoden.
Svenska För att få en översättning av handboken på ditt språk, skanna QR-koden.

中国 要获取本手册以您的语言呈现的译本，
使用光盘或扫描QR代码。

How to access an available translation

The following documents are available on the website. Enter www.wmfts.com/product-documents into your web browser or scan the QR code found on the pump nameplate:

- User manual
- Quick reference instructions for the replacement of the pump hose

Note: The replacement instructions are only for users that are familiar with the replacement procedures in the user manual.

System requirements

Source	Hardware	Software
Website	PC or tablet	Internet browser
		PDF reader
QR code	Smartphone or tablet with camera	Internet browser
		PDF reader
		App that can scan QR codes

How to use the website

1. Go to the website www.wmfts.com and select the 'Literature' tab.
2. Select Brand 'Bredel' and Document Type 'Manual' and then the required language.
3. Open or save the user manual.

The PDF reader program shows the selected user manual.

How to use the QR code

1. Scan the QR code with your smartphone or tablet - The app forwards you to the webpage that contains the required language.
2. Open or save the user manual - The PDF reader program shows the selected user manual.

1 General

1.1 How to use this manual

This manual is intended as a reference book by means of which qualified users are able to install, commission and maintain the hose pumps Bredel 10, Bredel 15, and Bredel 20.

1.2 Original instructions

The original instructions for this manual have been written in English. Other language versions of this manual are a translation of the original instructions.

1.3 Other supplied documentation

Documentation of components such as the gearbox, the motor, and the frequency controller is not included in this manual. However, if additional documentation is supplied, you must follow the instructions in this additional documentation.

1.4 Service and support

Some specific adjustments, installation and maintenance or repair jobs fall beyond the scope of this manual. In case of doubt, consult your Bredel representative.

Make sure that you have the following data at hand:

- Serial number of the hose pump
- Part number of the pump hose
- Part number of the gearbox
- Part number of the electric motor
- Part number of the frequency controller

You will find these data on the identification plates or stickers on the pumphead, the pump hose, the gearbox, and the electric motor.

See also

Refer to "Description" on page 12

1.5 Environment and disposal of waste

Note: Always observe the local rules and regulations with respect to processing (non reusable) parts of the hose pump.



WARNING

Risk of poisoning and environmental damage. Pump parts can get contaminated by pumped liquids to such an extent that cleaning becomes insufficient. Dispose of contaminated parts according to local regulations.

When you discard items, obey these instructions:

- Use suitable personal protective equipment.
- Obey the safety instructions of the working environment.
- Obey the safety, health, and waste sorting instructions of the product.
- Drain, collect, and dispose of the lubricant in accordance with local rules and regulations.
- Collect and dispose of any leaking pumped liquid or oil in accordance with local rules and regulations.
- Neutralize residues of pumped liquid in the pump.
- Dispose of the parts in accordance with local rules and regulations.

Enquire within your local government about the possibilities for reuse or environment-friendly processing of packaging materials, (contaminated) lubricant, and oil.

2 Safety

2.1 Symbols

In this manual the following symbols are used:



WARNING

Procedures which, if not carried out with the necessary care, may result in serious bodily harm.



CAUTION

Procedures which, if not carried out with the necessary care, may result in serious damage to the hose pump, the surrounding area or the environment



Information on environmentally-friendly disposal or recycling of materials.



Procedures, remarks, suggestions or advice which refer to use in potentially explosive atmospheres in accordance with the ATEX Directive 2014/34/EU.

2.2 Intended use

The hose pump is exclusively designed for pumping suitable products. Every other or further use is not in conformance with the intended use. This is the use for which the technical product is intended in accordance with the specifications of the manufacturer, inclusive of his indications in the sales brochure. In case of doubt it is the use, which appears to be its intended use judging from the construction, execution and function of the product, and its description in the user's documentation.

Only use the pump in conformance with the intended use described above. The manufacturer cannot be held responsible for damage or harm resulting from use that is not in conformance with the intended use. If you want to change the application of your hose pump, contact your Bredel representative first.



WARNING

The pump is configured for use with specific fluids for which the chemical compatibility of the pump materials has been approved. Before using it in any application it is required to check the compatibility of the pump materials. Incompatible pumpehead material, hose liner, hose connections and lubricant can lead to serious damage and safety hazards. Always contact your Bredel representative first.

2.3 Use in potentially explosive atmospheres

The pumphead and drive mentioned in this manual may be configured to be suitable for use in a potentially explosive atmosphere. Such a pump meets the requirements as stated in the European Directive 2014/34/EU (ATEX Directive). These pumps have a maximum safety level of: Group II Appliances, category 2 GD bck T5. The actual safety level (ATEX code) depends on the options that are installed on the pump.



Use in potentially explosive atmospheres requires special configuration of the pump.

If the pump is to be used in potentially explosive atmospheres, contact your Bredel representative.

See also

Dedicated ATEX manual, part number 28-29210322.

2.4 NSF/ANSI 61 certification

For specific combinations of the hose and insert and in combination with certain chemicals, the hose pumps are configured and delivered in compliance with NSF International certification NSF/ANSI Standard 61: Drinking Water System Components – Health Effects and will bear the NSF mark shown below. A list of certified products and relevant chemicals can be found at <http://www.nsf.org/certified-products-systems>. For further details refer to the Bredel User Guide NSF 61 certified hose pumps supplied with such a pump, which can also be found on the website, or contact your Bredel representative for advice.



Certified to
NSF/ANSI 61

2.5 Responsibility

The manufacturer does not accept any responsibility for damage or harm caused by not observing the safety regulations and instructions in this manual and other supplied documentation, or by negligence during installation, use, maintenance and repair of the hose pumps mentioned on the front cover. Depending on the specific working conditions or accessories used, additional safety instructions can be required.

Immediately contact your Bredel representative for advice if you notice a potential danger while using your hose pump.



WARNING

The user of the hose pump is fully responsible for observing local safety regulations and directives. Observe these safety regulations and directives when using the hose pump.

2.6 Qualification of the user

The installation, use and maintenance of the hose pump should only be performed by well-trained and qualified users. Temporary staff and persons in training may use the hose pump only under the supervision and responsibility of trained and qualified users.

2.7 Regulations and instructions

- Ensure this manual can be easily accessed for safe operation and maintenance.
- Everyone who works with the hose pump must be aware of the contents of this manual and observe the instructions with great care.
- Never change the order of the actions to be carried out.

3 Warranty conditions

The manufacturer offers a two-year warranty on all parts of the hose pump. This means that all parts will be repaired or replaced free of charge, with the exception of consumables such as pump hoses, ball bearings, wear rings, seals and compression rings, or parts which have been used wrongly or have been misused, whether or not they have been intentionally damaged. If genuine Watson-Marlow Bredel B.V. (hereafter called Bredel) parts are not used, any warranty claim is void.

Damaged parts which are covered by the applicable warranty conditions can be returned to the manufacturer. The parts must be accompanied by a fully filled in and signed safety form as present in the back of this manual. The safety form must be applied to the outside of the shipping carton. Parts which have been contaminated or which have been corroded by chemicals or other substances which can pose a health risk must be cleaned before they are returned to the manufacturer. Furthermore, it should be indicated on the safety form which specific cleaning procedure has been followed, and that the equipment has been decontaminated. The safety form is required even if the parts have not been used.

Warranties purporting to be on behalf of Bredel made by any person, including representatives of Bredel, its subsidiaries, or its distributors, which do not accord with the terms of this warranty shall not be binding upon Bredel unless expressly approved in writing by a Director or Manager of Bredel.

4 Description

4.1 Identification of the product

The hose pump can be identified by identification plates or stickers on:

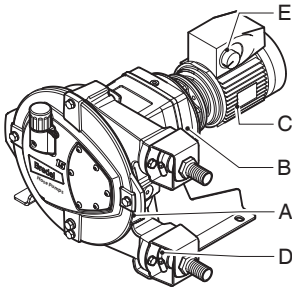

- | | | | |
|---|----------------|---|-------------------------------|
| A | Pumphead | D | Pump hose |
| B | Gearbox | E | Frequency controller (option) |
| C | Electric motor | | |

Identification of the pump

The identification plate on the pumphead contains the following data:

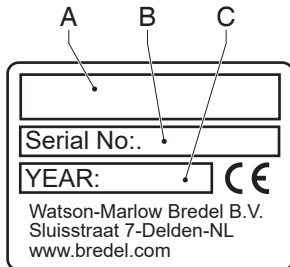

- | | | | |
|---|---|---|---------------|
| A | Pump type and rotor identification letter (Refer to "Identification of the rotor" on the next page) | B | Serial number |
| C | Year of manufacture | | |

Identification of the rotor

The rotor identification letter identifies which type of rotor is mounted to the pump. The table below shows the rotor identification letter and the part number of the mounted rotor.

Letter	Pressure range	Bredel 10	Bredel 15	Bredel 20
blank	-	no rotor	no rotor	no rotor
A	≤ 400 kPa	28-210103L	28-215103L	-
B	400 to 800 kPa	28-210103H	28-215103H	-
C	≤ 400 kPa	-	-	28-220103L
D	400 to 800 kPa	-	-	28-220103H
E	> 800 kPa	28-210103X	28-215103X	-
F	> 800 kPa	-	-	28-220103X

See also

Refer to "Maximum working pressure" on page 62.

Refer to "Pumphead assembly" on page 72.

Identification of the gearbox

The identification plate on the gearbox contains the following data:

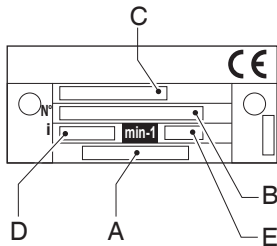

- | | | | |
|---|---------------|---|----------------------------------|
| A | Part number | D | Reduction ratio |
| B | Serial number | E | Number of revolutions per minute |
| C | Type number | | |

Identification of the electric motor

The identification plate on the electric motor contains the following data:

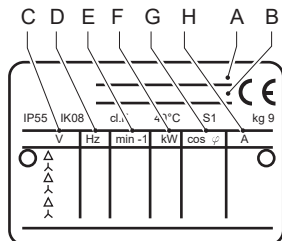

- A Part number
- B Serial number
- C Mains
- D Frequency

- E Speed
- F Power
- G Power factor
- H Current

Identification of the frequency controller

The identification of the Bredel Variable Frequency Drive (VFD) can be found inside the VFD. Remove the cover by loosening the two screws. The identification sticker contains the following data:

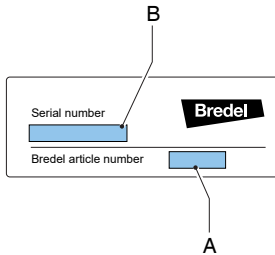

A Part number

B Manufacturer's serial number

Identification of the hose

The identification sticker on the pump hose contains the following data:

NR Metering hose

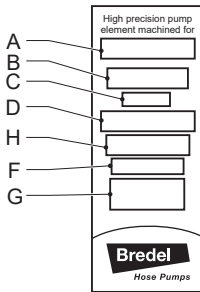

NR Transfer hose

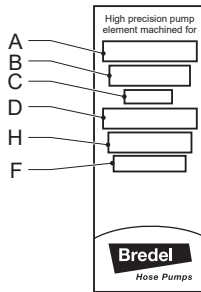

Other hoses

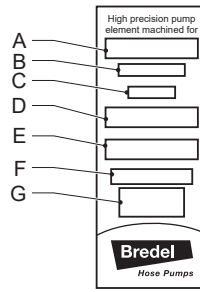

A Pump type

B Part number

C Internal diameter

D Type of material of inner liner

E Remarks, if applicable

F Maximum permissible working pressure

G Production code

H Hose type

4.2 Construction of the pump

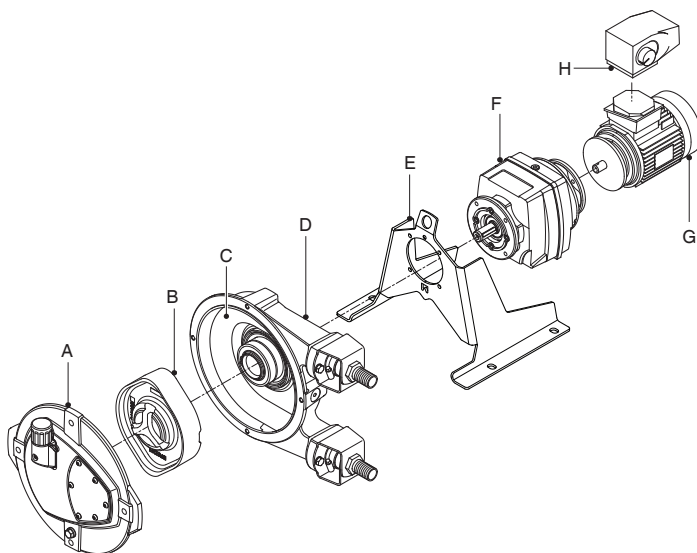

A Cover
B Rotor
C Hose
D Pump housing

E Support
F Gearbox
G Electric motor
H Frequency controller

4.3 Operation of the pump

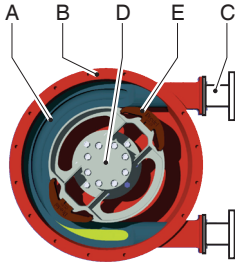

The heart of the pumphead consists of a specially constructed hose (A) which lies against the inside of the pump housing (B).

The ends of the hose are connected to the suction and discharge lines (C).

A rotor (D) with two facing pressing shoes (E) is in the centre of the pumphead. In this example, it rotates clockwise.

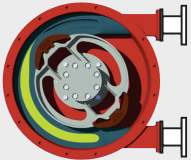
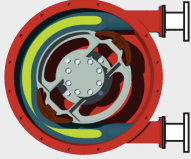
Phase	Description	Pump layout
1	The lower pressing shoe compresses the hose by the rotational movement of the rotor, forcing the fluid through the hose. As soon as the pressing shoe has passed, the hose recovers to its original shape sucking in new fluid.	
2	When the first pressing shoe leaves the pump hose, the second pressing shoe has already occluded the hose and fluid is prevented from flowing back. This method of liquid displacement is known as the "positive displacement principle".	

4.4 Pump installation positions

The pump can be delivered with the following possible pumphead installation positions:

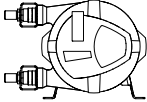
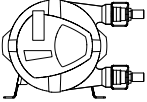
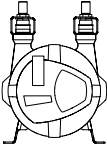
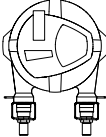
Position	Description	Pump layout
1	Pump ports at left hand side when facing the pump at the cover.	
2	Pump ports at right hand side when facing the pump at the cover.	
3	Pump ports facing upwards.	
4	Pump ports facing downwards.	

Concerning pumps Bredel 10, Bredel 15, and Bredel 20 the position of the cover is equal for all pump positions, as indicated by the position of the inspection window in the illustrations above. An accurate reading of the lubricant level through the inspection window is possible at every pump position.

At every pump position, operational rotation of the rotor is possible in both directions. In this manual the illustrations are based on pumphead position 2.

4.5 Hose

General

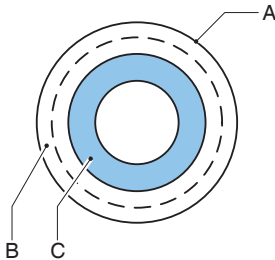

- A Extruded or wrapped outer layer made of natural rubber C Extruded or wrapped inner liner
B Nylon reinforcement layers

The hose liner material should be chemically resistant to the process fluid being pumped. For each pump model various hose types are available. Choose the most appropriate for your application.

The material of the inner liner of the hose determines the hose type. Each hose type is marked by a unique colour code.

Liner type / material	Label colour
NR	Purple
NBR, NBR-F*, F-NBR*	Yellow
EPDM	Red
CSM	Blue

*See also

Dedicated manuals:

NBR hoses for food contact, part number 28-29211330

F-NBR hoses for food contact, part number 28-29211322

Note: Contact your Bredel representative for advice about the chemical and temperature resistance of the hoses.

The Bredel hoses are carefully manufactured and quality checked to achieve minimum tolerances in wall thickness.

It is very important to guarantee the correct compression of the hose, because:

- When the compression is too high, it creates an excessive load on the pump and hose, which may reduce the life of the hose and bearings.
- When the compression is too low, it cuts capacity and causes backflow. Backflow reduces the life of the hose.

Hose compression force adjustment

The compression force on the pump hose can be adjusted by installing a rotor with a different dimension between the tips of the integral pressing shoes. The rotor is chosen to achieve an optimal life of the pump hose for the intended use of the hose pump.

If you want to change the application of your hose pump or if you want to change the hose size, contact your Bredel representative for advice.

See also

Refer to "Maximum working pressure" on page 62.

Lubrication and cooling

The pumphead is filled with Bredel Genuine Hose Lubricant. This lubricant lubricates the pressing shoes and dissipates the generated heat via the pump and the cover.

The user is responsible to ensure the chemical compatibility of the lubricant with the fluid to be pumped.

See also

Refer to "Lubricant table pump" on page 64 for the required quantity and NSF registration.

Refer to "Hose failure" on page 33 for the consequences of a hose failure.

Note: Consult your Bredel representative for advice on lubrication when operating the hose pump below 2 rpm.

4.6 Gearbox

The hose pump types described in this manual use helical gearbox units.

The gearboxes are fitted with a flange connection.

See also

Refer to "Gearbox" on page 67

If the pump is to be used in potentially explosive atmospheres: Refer to "Use in potentially explosive atmospheres" on page 9

4.7 Electric motor

If the electric motor has been standard supplied by the manufacturer, it is a standardized squirrel-cage motor.

See also

If the pump is to be used in potentially explosive atmospheres, Refer to "Use in potentially explosive atmospheres" on page 9

Refer to "Specifications" on page 61

4.8 Frequency controller

Refer to the documentation supplied by the manufacturer.

See also

If the pump is to be used in potentially explosive atmospheres, Refer to "Use in potentially explosive atmospheres" on page 9

Refer to "Specifications" on page 61

Use of electric and electronic devices like electric motor and frequency controller require special configurations. Sometimes use is limited to non-ATEX only. In case of doubt, consult your Bredel representative..

4.9 Available options

The following options are available for the hose pump:

- High (lubricant) level float switch
- Revolution counter
- Low, medium, or high pressure rotor
- Bare shaft version
- Frequency controller
- Special configuration for use in potentially explosive atmospheres

5 Installation

5.1 Unpacking and inspection

Unpacking

1. Unpack all parts carefully.
2. Retaining packaging until inspection is complete.

Inspection

1. Check all components present
2. Inspect components for damage in transit
3. Report missing components or damage to your local Bredel representative immediately

Packaging disposal

Dispose of packaging materials:

1. Safely
2. Responsibly
3. Recycle outer carton (corrugated cardboard)
4. Compliant to all relevant regulations

5.2 Installation conditions

Ambient conditions

Make sure that the hose pump is in an area where the ambient temperature during operation is not lower than -20 °C and not higher than +45 °C.

Installation site

Installation specifications

Do not exceed ambient operating air temperature range (°C)	-20 °C to +45 °C
Maximum floor slope (mm per metre)	50

Note: Pump is suitable for indoor use. In case of outdoor use contact your Bredel representative for advice.

Set-up

Installation site requirements:

- Flat
- Horizontal
- Rigid surface
- Rated to support full weight of complete assembly and pumped product
- Allow a free flow of air around the pump, gearbox and electric motor to dissipate heat
- Ensure sufficient access for all maintenance
- Free from excessive vibration

Pipework

- The bore size of the suction and discharge lines must be larger than the bore size of the pump hose. In case of doubt, consult your Bredel representative.
- Avoid sharp bends in the discharge line. Make sure that the radius of the bent discharge line is as large as possible. It is recommended to use Y-connections instead of T-connections.
- Keep the delivery and suction lines as short and direct as possible.
- Select the correct mounting material for flexible hoses and make sure that the installation is suited for the design pressure of the system.
- Do not exceed the maximum working pressure of the hose pump.
- Prevent the valves in the suction and discharge lines from being shut while the pump is running.

See also

Refer to "Performance" on page 61



CAUTION

Consider the maximum permissible working pressure on the discharge side. Exceeding the maximum working pressure may lead to serious damage to the pump.

- Contact your Bredel representative for advice on mounting pulsation dampening devices. A pulsation dampener and/or inlet pulse accumulator may be necessary if the relative density and pump speed is high and the line lengths are long.
- The self-priming and positive displacement nature of peristaltic pumps means that valves are not required. If for whatever reason valves are fitted into the system, they must have a straight fluid path and cause minimum restriction to flow in the pumping circuit. Note that the presence of check valves directly in the process stream may increase pulsation and negatively impact hose life.
- For the ease of hose changing and some pulsation suppression, it is recommended to use a segment of flexible hose between the pump flange and hard piping of the suction and/or discharge line. A segment of three quarters (3/4) of the pump hose length for the flexible pipe work is recommended. Bredel also recommends installing an isolation valve and pipedrain in the suction and discharge pipework to allow fluid isolation and drainage from the pump during maintenance. Following these recommendations will help to minimize the exposure of process fluid to maintenance personnel.
- Make sure that the maximum forces on the flanges are not exceeded. The permissible loads are given in the following table.

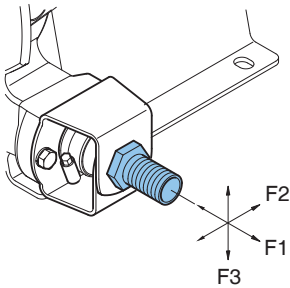

Maximum permissible loads [N] on the pump flange

Force	Bredel 10	Bredel 15	Bredel 20
F1	600	600	600
F2	300	300	300
F3	120	120	120

Frequency controller



WARNING

A frequency controller that is fitted without manual control can start the pump automatically when power is applied.

If the hose pump is fitted with a frequency controller, consider the following points:

- Take precautions so the motor does not restart automatically after an unscheduled stop. In the event of a power or mechanical failure, the frequency controller stops the motor. When the cause of the failure is removed, the motor can restart automatically. The automatic restart can be dangerous in certain pump installations.
- All control cables outside the enclosure must be shielded and have a cross sectional area of at least 0.22mm². The shielding must be connected to earth at one end. In case of doubt, contact your Bredel representative for advice.

5.3 Lifting and moving the pump



Lifting should be performed according to standard Health and Safety guidelines and should be performed by qualified personnel only.

Use the lifting eye (A) on the pump support to lift and move the hose pump.

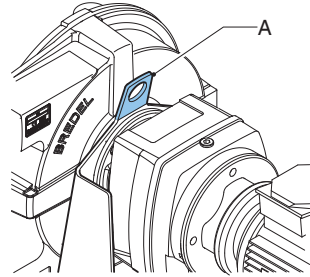

The complete hose pump (the pumphead, gearbox and electric motor) must be lifted using the lifting eye plus additional support using suitably rated straps or slings (A).

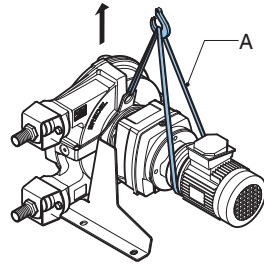

5.4 Placing the pump



Do not use holes (B) when the pump is placed on the levelling elements. This can cause the pump to tilt.



Do not use the holes in the pump supports to lift the hose pump.

The pump can be fixed to the floor using anchors. Alternatively the pump can be placed on the floor using levelling elements.

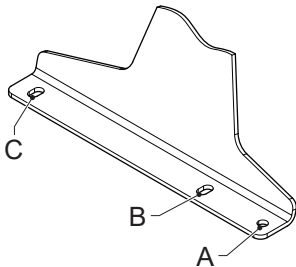

- In case of fixing to the floor use holes (A) or (B) and holes (C) at both sides of the pump.
- In case of levelling elements, use holes (A) and holes (C) at both sides of the pump.

Note: If the pump installation position is in position 4, then the use of levelling elements is not possible.

Using anchor bolts

Position the pump on a horizontal surface. Use suitable anchor bolts to attach the pump to the floor surface.

Follow the next steps to make sure the anchor bolts are used properly. Use the specifications below.

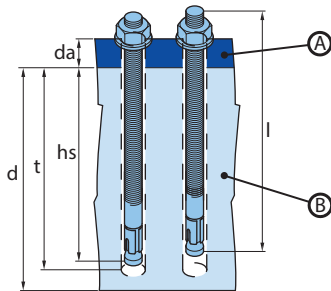

A. Pump support

B. Foundation

1. Drill the holes.
2. Clean the bore holes.
3. Use a hammer to drive the anchor bolt into the bore.
4. Tighten the bolt to the applicable torque setting (MD).

Item	Unit	Bredel 10-20
Flange thickness (d_a)	mm	4
Flange hole diameter	mm	12 x 16
Bredel part no.	-	28-F550016
Bolt thread	-	M10
Bolt length (l)	mm	85
Minimum foundation height (d)	mm	200
Drill diameter	mm	10
Minimum drill depth (h)	mm	70
Mounting depth (hs)	mm	60

Item	Unit	Bredel 10-20
Torque setting (MD)	Nm	30

Using levelling elements

Use four suitable levelling elements to place the pump on a horizontal surface. Adjust the elements such that the pump does not wobble and the weight of the pump is evenly spread over the elements at left hand and right hand sides.

Pump	Diameter holes (A) [mm]	Size holes (C) [mm]	Element thread diameter	Rated load capacity per element [kg]
Bredel 10	11	18x12	M10	50
Bredel 15-20	11	18x12	M10	70

6 Commissioning

6.1 Preparations



WARNING

A frequency controller that is fitted without manual control can start the pump automatically when power is applied.



WARNING

Disconnect and lock the power supply to the pump drive before any work is carried out. In case the motor is fitted with a frequency controller and has a single-phase power supply, wait two minutes to make sure that the capacitors have discharged.

1. Connect the electric motor and, if present, the frequency controller in conformance with the locally applicable rules and regulations. Have the electrical installation work carried out by qualified personnel.
2. Check that the lubricant level is above the minimum level line in the inspection window. If necessary refill with Bredel Genuine Hose Lubricant via the breather plug.

See also

Refer to "Frequency controller" on page 25

Refer to "Changing lubricant" on page 39

6.2 Commissioning

1. Connect the pipework.



CAUTION

Make sure that there are no obstructions such as closed valves.

2. Connect the pump to the electrical supply.
3. Switch on the electrical supply.
4. Check the rotation of the rotor.
5. Make sure that hose clamps are correctly fitted.
6. Check the capacity of the hose pump. If the capacity differs from your specification, follow the instructions in Troubleshooting or contact your Bredel representative for advice.
7. If a frequency controller is present, check the capacity range. In case of any deviations consult the supplier's documentation.
8. Check the hose pump in accordance with points 2 to 4 of the maintenance table.

See also

Refer to "Maintenance and periodic inspections" on page 36

Refer to "Tightening the hose clamps" on page 43 for how to tighten the hose clamps

Refer to "Troubleshooting" on page 56

7 Operation

7.1 Temperature

The pump will heat up during normal operation. This will result in a temperature higher than the ambient temperature.



WARNING

Avoid contact with the casing and cover under conditions of high pressure and running speed.

7.2 Power rating

Drive power and reduction ratio determine the pump operating condition.

See also

Refer to "Performance graphs" below to determine the required power.



WARNING

Overloading the motor can lead to serious motor damage. Do not exceed the maximum power rating of the motor.



WARNING

Overloading the gearbox leads to increased tooth wear and shortened bearing life. This can lead to serious gearbox damage. Do not exceed the maximum power rating of the gearbox.

7.3 Performance graphs

The pump and hose are designed to handle a discharge pressure up to 1000 or 1200 kPa. The triangular area between the 0 kPa and the 1000 or 1200 kPa lines describes the allowed performance area. The required duty points have to fall within this area. For discharge pressures lower than 0 kPa use the 0 kPa line.

In the direction of higher speeds and powers, pump operation is limited by the heat generated, the product temperature and the ambient temperature. Product temperature lines determine a distinction between areas of continuous operation and intermittent operation in the graphs. The graphs apply for a maximum ambient temperature of 45 °C.

If the duty for an application is specified in the area of intermittent operation, let the pump stand still to cool down for at least one hour after two hours of operation.

How to use the graphs

Required motor power in kW (HP)

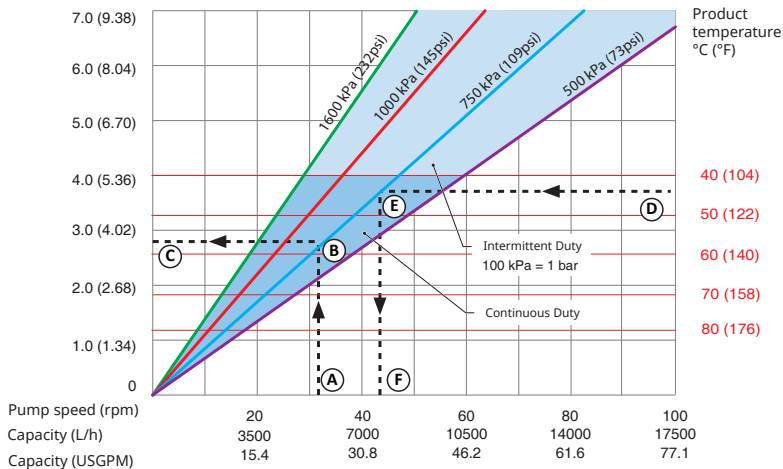

- | | |
|-------------------------------|-------------------------------|
| A Required flow or pump speed | D Product temperature |
| B Required discharge pressure | E Required discharge pressure |
| C Required motor power | F Maximum allowed pump speed |

Refer to the graph to understand how to use the graphs to determine the required motor power or the maximum allowed pump speed.

To determine the required motor power:

1. Start at the required flow or pump speed (A).
2. Meet the line of the required discharge pressure (B).
3. Read the required motor power (C).

To determine the maximum allowed pump speed:

1. Start at the product temperature (D)
2. Meet the line of the required discharge pressure (E).
3. Read the maximum allowed pump speed (F).

Note: Pump stroke volume is based on new hoses and flooded suction. Actual stroke volume may vary.

Performance graph Bredel 10

Bredel 10

Required motor power in kW (HP)

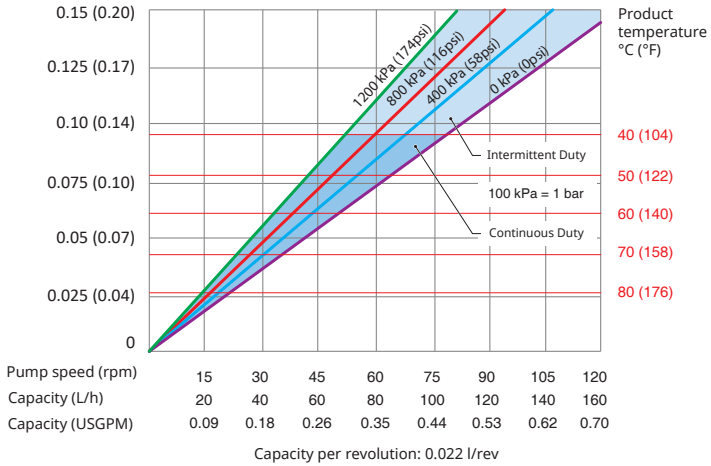

Performance graph Bredel 15

Bredel 15

Required motor power in kW (HP)

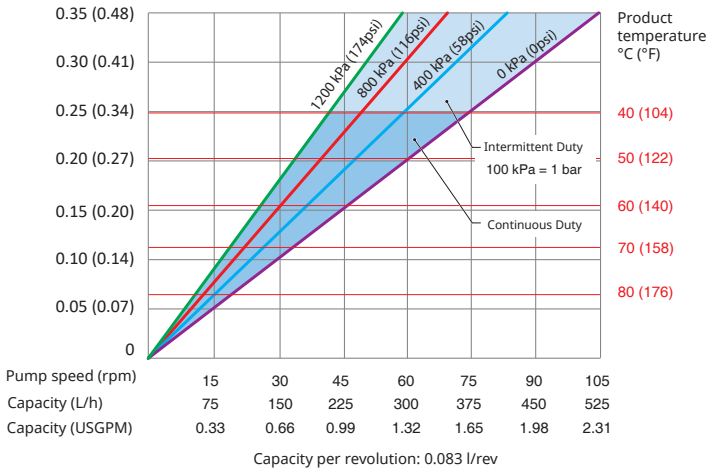

Performance graph Breedel 20

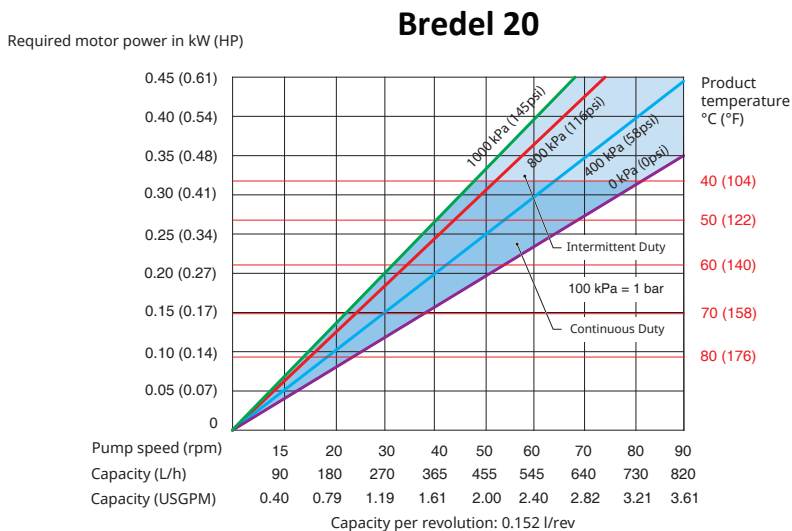

7.4 Dry running

Dry running is a running condition of the pump when no fluid is flowing through the hose. Breedel hose pumps allow dry running for limited periods.

Dry running imposes an additional thermal load on the hose.

To minimise the extra wear, limit dry running periods to less than one minute at a time.

7.5 Hose failure

Cause of a hose failure

The hose in a peristaltic pump has to withstand many load cycles of compression. The repetitive stress cycles will cause the hose to deteriorate and eventually fail.

Result of a hose failure

A hose failure will result in direct contact between the pumped fluid and the pump lubricant, the internal parts, and the dynamic seal.

Consequences of a hose failure

Process fluid can enter and contaminate the pump housing and lubricant. Thoroughly clean the interior before installing a new hose.

In general, this will not cause a hazardous situation because the Bredel Genuine Hose Lubricant is harmless (approved by the United States Food and Drug Administration). However, there is an exception in case of pumping a strong oxidiser or a strong acid. For example, sodium hypochlorite (NaClO), this can lead to exothermal reaction.

In case of doubt contact your Bredel representative.

See also

Refer to "Lubricant pump" on page 1



WARNING

Avoid direct contact between a strong oxidiser or a strong acid and Bredel Genuine Hose Lubricant. This can cause unwanted chemical reactions. Use an alternative lubricant to avoid hazardous situations. In case of doubt, consult your Bredel representative..

Note: Regularly replace the hose to avoid hose failure and additional downtime. Hose life depends on the operating condition, process fluid and hose material. The end-user should be aware of this and establish the frequency of preventive hose replacement. In case of doubt, consult your Bredel representative.

Large spill of product

Stop pump immediatly.

Operation after hose failure can lead to large spill of product.

It is strongly recommended to install a high level float switch.

See also

Refer to "Fitting options" on page 52

Install a check valve to prevent reverse flow when all following conditions occur simultaneously

- Hose fails
- Pump stops
- Process pressure exceeds ambient levels

7.6 Fluid leakage

The pump uses a lubricated rotor to compress the hose. This means the pumphead must be filled with sufficient lubricant during operation. This lubricant is contained in the pump housing by the front cover and by a dynamic seal on the back. The gearbox is filled with gearbox lubricant.

Seal damage can occur due to normal wear in time, but is seriously accelerated if the seal gets in contact with contaminated lubricant. Thorough cleaning of the pump housing after a hose failure and regular replacement of the lubricant is strongly advised.

Note: Regularly check the pumphead for any leakage around the cover, the hose connections, and the rear of the pumphead.

The pumphead and gearbox are directly coupled to each other. A special feature is included in the pumphead to allow early detection of seal damage of the pump or gearbox.

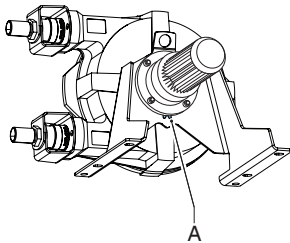

This feature is called the leakage zone (A). Drops of lubricant visible at the back of the pump indicate likely seal failure. To avoid consequential damage, the pump must be stopped and lubricant levels of the pumphead and gearbox must be checked. The damaged seal should be replaced.



WARNING

Risk of injury from falling! Process fluid mixed with pump lubricant that is leaking from the pump can make floors slippery.

8 Maintenance

8.1 General



WARNING

Disconnect and lock the power supply to the pump drive before any work is carried out. In case the motor is fitted with a frequency controller and has a single-phase power supply, wait two minutes to make sure that the capacitors have discharged.



WARNING

Do not remove the pump cover if the power cable is connected to the motor. Do not connect the power cable to the motor if the pump cover is removed.



CAUTION

Only use original Bredel parts when maintaining the hose pump. Bredel cannot guarantee correct operation and any consequential damage that occurs from the use of non-original Bredel components.



CAUTION

Check that all components are present. Inspect components for damage in transit. If anything is missing or damaged, contact your distributor immediately.

Note: Do not install damaged parts. If in doubt, contact your Bredel representative for advice.

8.2 Maintenance and periodic inspections

The following maintenance schedule shows the maintenance and periodic inspection that need to be carried out on the hose pump to guarantee optimal safety, operation and life of the pump.

Note: It is also necessary to carry out periodic inspection of the gearbox and the electric motor. Consult their separate manuals to guarantee an optimal safety, operation and life of the gearbox and the electric motor.

Item	Action	To be carried out	Remark
1.	Check the lubricant level.	Before start-up of the pump and at scheduled intervals during operation.	Check that the lubricant level is above the minimum level line in the inspection window. If necessary refill with Bredel Genuine Hose Lubricant via the breather plug. Refer to "Changing lubricant" on page 39
2.	Regularly check the pumphead for any leakage around the cover, the hose connections, and the rear of the pumphead.	Before start-up of the pump and at scheduled intervals during operation.	Refer to "Troubleshooting" on page 56
3.	Check the gearbox for any leakage.	Before start-up of the pump and at scheduled intervals during operation.	In case of doubt, consult your Bredel representative.
4.	Check the pump for deviating temperature or strange noises.	At scheduled intervals during operation.	Refer to "Troubleshooting" on page 56
5.	Check the rotor with integral pressing shoes for excessive wear.	When replacing the hose.	Refer to "Fitting the hose" on page 49
6.	Internal cleaning of the hose.	Cleaning of the system or fluid change.	Refer to "Cleaning the hose" on the next page
7.	Replace the hose.	Preventive, this means after 75% of the hose life of the first hose.	Refer to "Changing the hose" on page 40
8.	Change the lubricant.	After every second hose change, after 5000 service hours, after a year or after hose rupture whichever comes first.	Refer to "Changing lubricant" on page 39

Item	Action	To be carried out	Remark
9.	Replace the seal ring	If necessary	Refer to "Exchanging replacement parts" on page 44
10.	Replace the rotor with integral pressing shoes.	If there is wear on the running surface of the hose and/or seal ring.	Under normal operating conditions replacement is hardly required. Refer to "Exchanging replacement parts" on page 44
11.	Replace the bearings.	If necessary.	Refer to "Exchanging replacement parts" on page 44

8.3 Additional maintenance in potentially explosive environments

The following maintenance scheme shows the additional maintenance and periodic inspections that need to be carried out on the hose pump to guarantee an optimal safety, operation and life of the pump in a potentially explosive environment. Refer to the separate ATEX manual, part number 28-29210322.

Action	To be carried out	Remark
Replace the bearings.	According to ATEX regulations after 40,000 hrs. service or when damage is suspected.	Refer to "Exchanging replacement parts" on page 44
Clean the hose pump.	In potentially explosive (dust) atmospheres, the dust must be removed regularly.	

8.4 Cleaning the hose

With a lot of product fluids it is necessary to have the hose cleaned immediately after the pumping process to avoid hardening of the fluid inside. The inside of the hose can be easily cleaned by rinsing the pump with clean water. If a cleaning agent is added to the water, check if the hose liner material is resistant to it. Also check if the hose can resist the cleaning temperature. Special cleaning sponge balls are also available. Refer to the documentation of the cleaning products and the hose for more information.

A proper result of a cleaning process in this way is not guaranteed by Bredel, while it strongly depends on the type of pumped fluid and the cleaning fluid applied.

For food applications, cleaning procedures are more strict. Refer to the documentation supplied with the food hose.

In case of doubt, consult your Bredel representative.

8.5 Changing lubricant

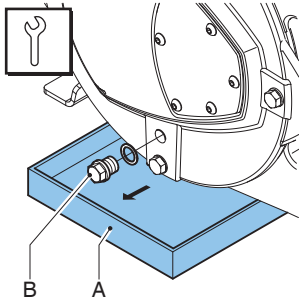

Note: The drain plug is in the cover of the pump.

1. Place a tray (A) under the drain plug. The tray must be large enough to contain the lubricant, possibly contaminated with product fluid, from the pumphead. Remove the drain plug (B). Collect the lubricant from the pump housing in the tray.
2. Position the drain plug and tighten it to the specified torque.

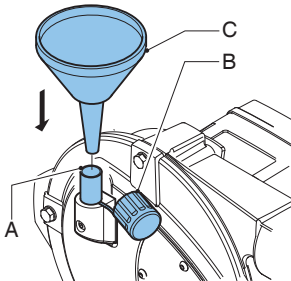

3. The pump housing can be filled with lubricant via the breather (A). For this purpose remove the breather cap (B) and position a funnel (C) in the breather. Pour the lubricant into the pump housing through the funnel.

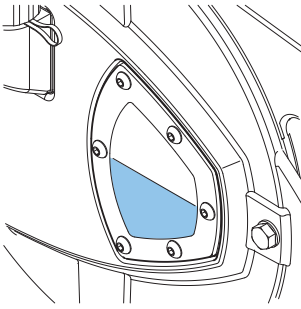

4. Keep on pouring until the lubricant level has risen above the level line in the inspection window. Place back the breather cap.

See also

For the required quantity of lubricant, Refer to "Lubricant table pump" on page 64

Refer to "Torque figures" on page 66

8.6 Changing the hose

Removing the hose

1. Isolate the pump from the electrical supply.
2. Close any shut-off valves in the suction and discharge line to minimise the loss of process fluid.

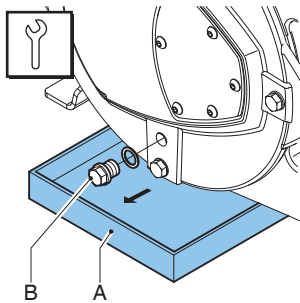

Note: The drain plug is in the cover of the pump.

3. Place a tray (A) under the drain plug. The tray must be large enough to contain the lubricant, possibly contaminated with product fluid, from the pumphead. Remove the drain plug (B). Collect the lubricant from the pump housing in the tray.
4. Position the drain plug and tighten it to the specified torque.
5. Disconnect the suction and discharge lines.

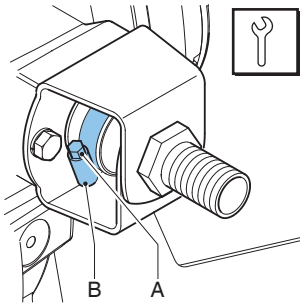

6. Loosen the hose clamp (A) of both the inlet and outlet ports by loosening the retaining bolt (B).

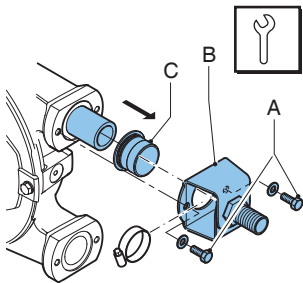

7. Loosen the retaining bolts (A) of the bracket (B) and remove the bolts.
8. Pull the bracket and the hose clamp from the hose. Then pull off the rubber bush (C). Do steps 7 and 8 both for the inlet and the outlet ports.
9. Connect the pump to the electrical supply.
10. Switch on the electrical supply.

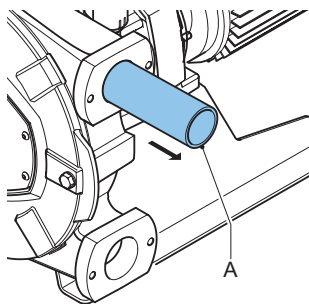

11. Power out the hose (A) from the pump chamber by jogging the drive motor.

WARNING



During jogging the drive:

- Do not stand in front of the pump ports.
- Do not try to guide the hose by hand.

See also

Refer to "Torque figures" on page 66

Cleaning the pumphead

1. Isolate the pump from the electrical supply.

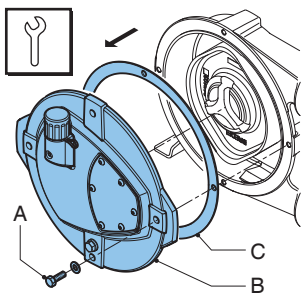

2. Remove the cover (B) by loosening the retaining bolts (A).
3. Check the gasket (C) for damage and replace it if necessary.

4. Rinse the pumphead with clean water and remove all residues. Make sure that no rinsing water remains in the pumphead.
5. Check the rotor for wear or damage and replace the rotor if necessary.

See also

Refer to "Maintenance and periodic inspections" on page 36



CAUTION

When the pressing shoes are worn the compression force of the hose decreases. If the compression force is too low, this results in a loss of capacity by the backflow of the liquid to be pumped.

Backflow results in a reduction of the life of the hose.

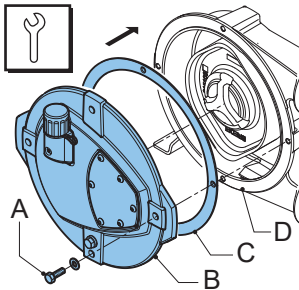

6. Place the gasket (C) on the pump housing (D).
7. Refit the cover (B). Make sure that the four bolts (A) are refitted and that they are tightened in the correct order, diagonally opposite each other.
8. Connect the pump to the electrical supply.
9. Switch on the electrical supply.

See also

Refer to "Torque figures" on page 66

Tightening the hose clamps

How to tighten hose clamps in combination with steel inserts

As a first step, apply the initial setup torque value of 3Nm. In some cases, an adjustment to the specified torque values is required. This can be due to excessive friction between the thread of the tightening bolt and the clamp. The actual clamping force needed can deviate from the clamping force derived from the specified torque values. To minimize this risk, it is advised to grease the clamping bolts.

If the specified torque values lead to a leaking hose connection, it is advised to carefully increase the bolt torque until a sealed situation is obtained. Here the absolute torque value is of less importance. In case of plastic inserts, the amount of clamping must be limited to avoid deformation of the plastic insert which would lead to leakage instead.

8.7 Exchanging replacement parts

Replacing the rotor bearings and seal ring

1. Remove the pump hose.
2. Isolate the pump from the electrical supply.

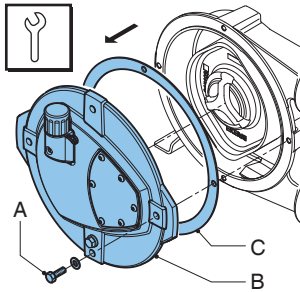

3. Remove the cover (B) by loosening the retaining bolts (A).
4. Check the gasket (C) for damage and replace it if necessary.

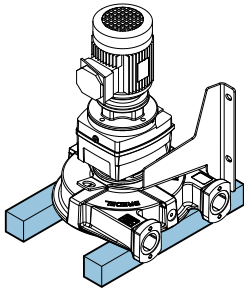

5. Put the pump on blocks. Make sure the space between the blocks is wide enough for the rotor to fall.

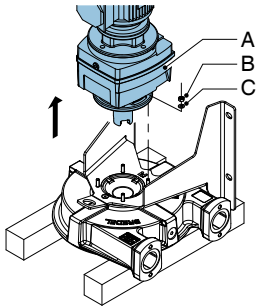

6. Remove the nuts (B), the washers (C) and the pump drive (A).

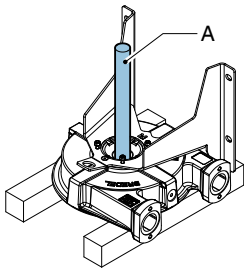

7. Put a plastic or wooden drive pin (A) on the rotor.
8. Hit the drive pin firmly with a hammer to remove the rotor.
9. Put the hose pump upright on the support.

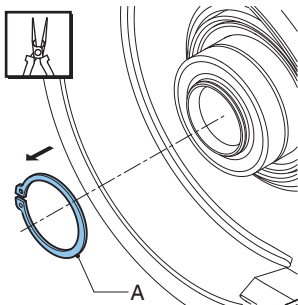

10. Dismount the retaining circlip (A) with the correct tool.

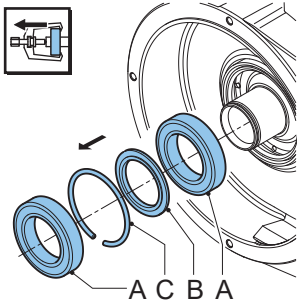

11. Remove the bearings (A), the spacer ring (B) and the retaining ring (C) with the correct tool.
12. Check that the hub is clean and free of grease.

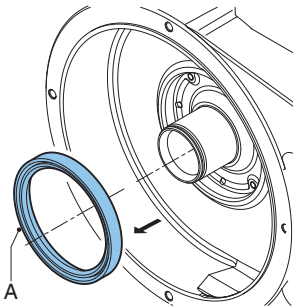

13. Remove the seal ring (A). Clean and degrease the bore.

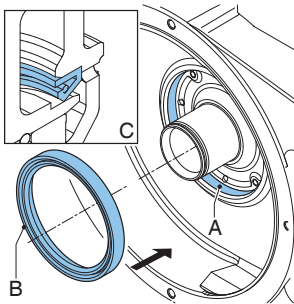

14. Gently press the new seal ring (B) into the cavity. The seal ring must be fitted in the correct orientation (C), with the open side towards the pump cover. If needed for ease of mounting, slightly oil the cavity area (A).
15. Slightly grease the seal lip of the dynamic seal (B).

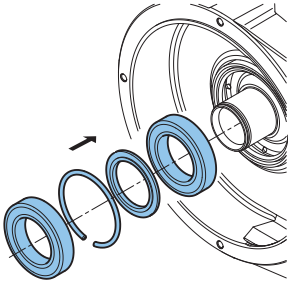

16. Slightly oil the inner ring of the (new) bearings and the seat on the hub. Fit the bearings and the rings. The bearings are placed on the hub with a slight interference fit. Use a pressing tool to press the bearings on the hub.

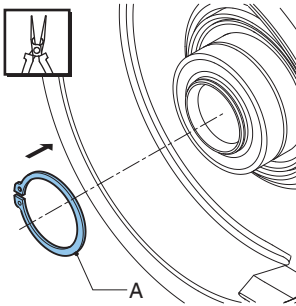

17. Check rotor retaining circlip (A) for any signs of damage and replace if necessary. Mount the retaining circlip (A). Use the correct tools for this purpose.

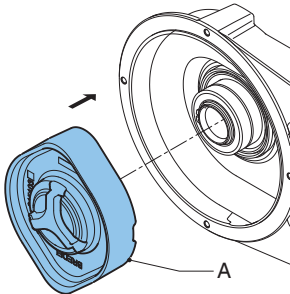

18. Fit the rotor (A). The rotor is placed on the bearings with a loose fit. Press the rotor on the hub until it clicks on the retaining ring.

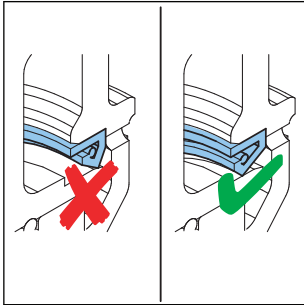

19. Check if the rotor can be turned by hand easily. If so, skip the next 2 steps. If turning requires excessive force, the lip of the seal is not properly positioned on the rotor seal area. Continue to the next step.
20. Remove the rotor.
21. Check that the seal is not damaged and replace it if necessary. Otherwise, If necessary, go to step 13 to replace the seal. Otherwise, go to step 18.
22. Put the pump on blocks.

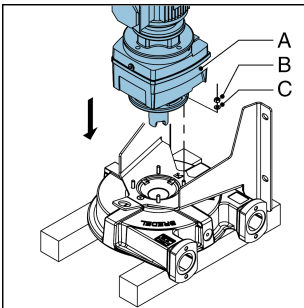

23. Fit the pump drive (A) with the nuts (B) and washers (C). Tighten to the specified torque settings.
24. Put the hose pump upright on the support.
25. Check the position of the rotor. If necessary press the rotor on the hub until it clicks on the retaining ring.

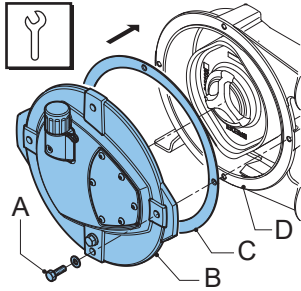

26. Place the seal (C) on the pump housing (D).
27. Refit the cover (B). Make sure that the four bolts (A) are refitted and that they are tightened in the correct order, diagonally opposite each other.
28. Connect the pump to the electrical supply.
29. Switch on the electrical supply.
30. Fit the (new) pump hose.

See also

Refer to "Torque figures" on page 66

Refer to "Changing the hose" on page 40

Refer to "Fitting the hose" below

8.8 Fitting the hose

1. Clean the (new) hose on the outside and fully lubricate the outside with Bredel Genuine Hose Lubricant.

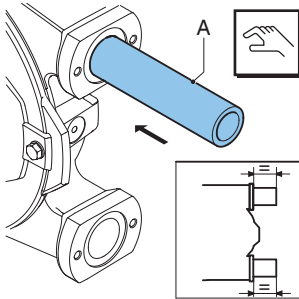

2. Fit the hose (A) via one of the ports.

- Run the motor so that the rotor pulls the hose into the pump housing. Stop the motor when the hose sticks out equally from both sides of the pump housing.

WARNING



During jogging the drive:

- **Do not stand in front of the pump ports.**
- **Do not try to guide the hose by hand.**

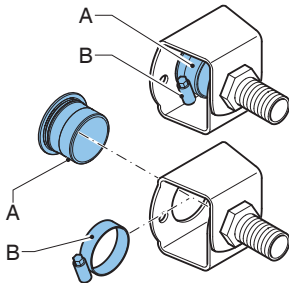

- Check that the rubber bushes (A) are not deformed or damaged and replace them if necessary.

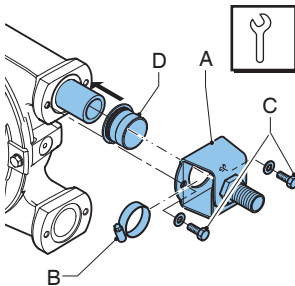

- Check that the hose clamps (B) are not damaged and replace them if necessary.
- First fit the inlet port. Slide the rubber bush (D) over the hose. Push the bracket (A) and the hose clamp (B) together over the hose. Align the holes in the bracket with the holes at the front of the port.
- Position the retaining bolts (C) and tighten them to the specified torque.

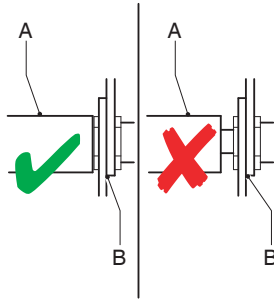

8. Turn the rotor in such a way that the hose (A) is pressed firmly against the bracket (B).

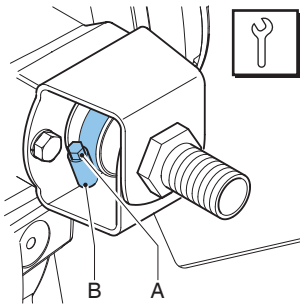

9. Tighten the bolt (A) of the hose clamp (B).
10. Now fit the other port. For this port proceed in the same way as described above for the inlet port.
11. Fill the pump housing with Bredel Genuine Hose Lubricant.
12. Connect the suction and discharge lines.

See also

Refer to "Torque figures" on page 66

Refer to "Removing the hose" on page 40

Refer to "Changing lubricant" on page 39

8.9 Fitting options

Fitting a high level float switch

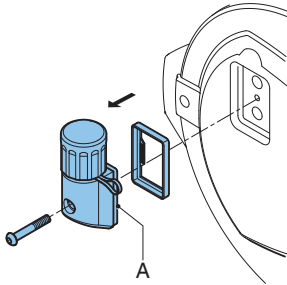

1. Dismount the standard breather (A) on the cover of the pumphead.

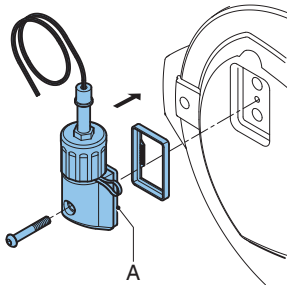

2. Mount the breather (A) with high-level float switch. Tighten the bolt to the specified torque.

See also

Refer to "Torque figures" on page 66

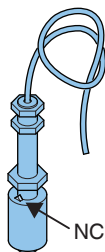

3. Connect the high-level float switch to the auxiliary power circuit via the 2 metre long PVC cable ($2 \times 0.34 \text{ mm}^2$). Bear in mind that the electrical contact of the float switch is normally closed (NC). The knob is upwards for normally closed operation. When the lubricant level is (too) high the contact will open.

Specifications*

Voltage	Max. 230 V AC/DC
Current	Max. 2 A
Power	Max. 40 VA

*For use in non-explosive atmospheres.

Note: Where the float switch is constructed to stop the equipment, operating has to be arranged so that the stop function locks out, preventing the equipment from being restarted without resetting. Check if the float switch is mounted with the NC sign at the top.

Fitting a revolution counter

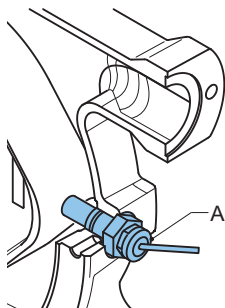

For feedback of the pump revolutions signal to an "intelligent" system, the pump can be equipped with an inductive sensor (A). This sensor is mounted between the two ports.

Connection of the revolution counter

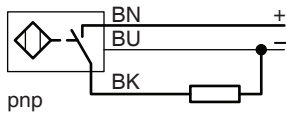

The speed sensor can be connected via the 2 meter long PVC cable (3 x 0.34 mm²).

Specifications

Voltage	10-65 V DC
Current	Max. 200 mA

*For use in non-explosive atmospheres.

Sensor adjustment

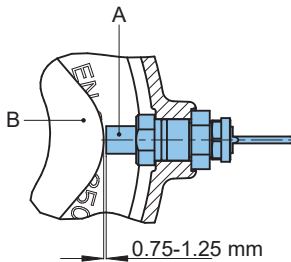

The sensor (A) must be adjusted at an offset of 0.75 - 1.25 mm to the rotor (B).

9 Storage

9.1 Hose pump

- Store the hose pump and pump parts in a dry area. Make sure that the hose pump and pump parts are not exposed to temperatures lower than -40 °C or higher than +70 °C.
- Cover the openings of the inlet and outlet ports.
- Prevent corrosion of untreated parts. For this purpose use the correct protection or packaging.
- After a long period of standstill or storage, the static load on the pump hose may have caused permanent deformation, which will reduce the life of the pump hose and may cause difficulty in starting. To prevent this, remove the pump hose when the pump is not going to be used for more than one month.



WARNING

Do not jog rotors with the electrical drive when the front cover is removed.

9.2 Hose

- The maximum shelf life for the hose is 2 years. Store the hose in a dark and dry place with temperatures between 0 °C and 40 °C. After two years the hose material will age, which will reduce the life of the hose.

9.3 Lubricant

- Replace the pump lubricant in case of failure of the pump hose and in any case after one year.
- Use the lubricant before the best-before date marked on the container.
- The lubricant must be stored in closed bottles or cans to avoid absorption of moisture.

10 Troubleshooting



WARNING

Disconnect and lock out the power supply to the pump drive before any work is carried out. In case the motor is fitted with a frequency controller and has a single-phase power supply, wait two minutes to make sure that the capacitors have discharged.

If the hose pump does not function (correctly), consult the following check list to see if you can remedy the error yourself. If you cannot, contact your Bredel representative for advice.

Problem	Possible cause	Correction
Failure to operate.	No voltage.	Check if the power supply switch is on.
		Check if the electrical supply is available at the pump.
	Stalled rotor.	Check if the pump is stalled by incorrect fitting of the hose.
		Check any possible blockage inside the hose.
Lubricant level monitoring system has been activated.	Check the frequency controller settings, if applicable.	
	Check if the lubricant level monitoring system has stalled the pump.	
		Check the functioning of the lubricant level monitoring system, and check the lubricant level.

Problem	Possible cause	Correction
High pump temperature.	Non-standard hose lubricant used.	In case of doubt, consult your Bredel representative.
	Low lubricant level.	Add Bredel Genuine Hose Lubricant. For the required amount of lubricant Refer to "Lubricant table pump" on page 64
	Product temperature too high.	Check the performance graph. Refer to "Performance graphs" on page 30
	Internal friction on the hose caused by blocked or poor suction characteristics.	Check pipework/ valves for blockages. Ensure that the suction pipework is as short as possible and that the diameter is large enough.
	High pump speed.	Reduce pump speed to a minimum. Contact your Bredel representative for advice on optimum pump speeds.
Low capacity / pressure.	Shut-off valve in the suction line (partly) closed.	Fully open the shutoff valve.
	Hose rupture or badly worn hose.	Replace the hose. Refer to "Changing the hose" on page 40
	(Partial) blockage of the suction line or too little product on the suction side.	Ensure that the suction line is clear of blockages and that sufficient product is available.
	Connections and hose clamps not correctly mounted, which makes the pump suck air.	Check the connections and the hose clamps. Tighten if necessary.
	The filling degree of the pump hose is too low, because the speed is too high in relation to the viscosity of the product to be pumped and the inlet pressure. The suction line can be too long or too narrow or a combination of these factors.	In case of doubt, consult your Bredel representative.
	Severely worn pump rotor	Check dimensions and surface condition of the rotor. Replace if necessary.

Problem	Possible cause	Correction
Vibration of the pump and pipework.	Suction and discharge lines are not secured correctly.	Check and secure pipework.
	High pump speed with long suction and discharge lines or high relative density or a combination of these factors.	Reduce pump speed. Reduce the line lengths on both suction and discharge where possible. In case of doubt, consult your Bredel representative.
	Too narrow diameter of suction and/or discharge line.	Increase the diameter of the suction/ discharge lines.
Short hose life.	Chemical attack of the hose.	Check the compatibility of the hose material with the product to be pumped. In case of doubt, consult your Bredel representative.
	High pump speed.	Reduce pump speed.
	High discharge pressures.	Maximum working pressure depends on the hose type. Check that the discharge line is not blocked, the shut-off valves are fully opened and the pressure relief valve functions properly (if present in the discharge line).
	High product temperature.	In case of doubt, consult your Bredel representative.
	High pulsations.	Restructure the discharge and inlet conditions.

Problem	Possible cause	Correction
Hose pulled into the pump.	Insufficient or no hose lubricant in the pumphead.	Add extra lubricant. Refer to "Changing lubricant" on page 39.
	Incorrect lubricant: no Bredel Genuine Hose Lubricant in the pumphead.	In case of doubt, consult your Bredel representative.
	hose clamp insufficiently tightened.	Adjust specified torque. Refer to "Tightening the hose clamps" on page 43.
	Extremely high inlet pressure - larger than 200 kPa.	Reduce the inlet pressure.
	Hose blocked by an incompressible object in the hose. The hose cannot be compressed and will be pulled into the pump housing.	Remove hose, check for blockages and replace if necessary.
Lubricant leakage at bracket.	Bolts of the bracket are loose.	Tighten to the specified torque settings. Refer to "Torque figures" on page 66
	Bolts of the hose clamps are loose.	Tighten the hose clamps. Refer to "Tightening the hose clamps" on page 43
	Rubber bush damaged or not properly positioned in the bracket.	Inspect rubber bush and replace if necessary. Lubricate the bush with Bredel Genuine Hose Lubricant before installation. Tighten the clamp according instructions. Refer to Refer to "Tightening the hose clamps" on page 43
Leakage from the rear of the pump housing "Buffer zone".	Damaged seal ring.	Replace seal ring.

Problem	Possible cause	Correction
Leakage of product medium between the hose and the insert.	Steel insert: the hose clamp is not tightened strong enough.	Refer to "Tightening the hose clamps" on page 43 for the procedure and correct torque value.
	Plastic insert: the hose clamp is tightened too much and as a result the insert is deformed.	Loosen the hose clamp and inspect the insert. Replace the insert if necessary. Refer to "Tightening the hose clamps" on page 43

11 Specifications

11.1 Pumphead

Performance

Description	Bredel 10	Bredel 15	Bredel 20
Hose inner diameter [mm]	10	15	20
Max. capacity, continuous [m ³ /h]	0.11	0.37	0.60
Max. capacity, intermittent [m ³ /h] *	0.16	0.52	0.82
Capacity per revolution [l/ rev]	0.022	0.083	0.152
Max. permissible inlet pressure [kPa]	200	200	200
Max. working pressure [kPa]	Refer to "Maximum working pressure" on the next page		
Permissible ambient temperature min [°C]		-20	
Permissible ambient temperature max [°C]		45	
Permissible product temperature min [°C]		-10	
Permissible product temperature max [°C]		80	
Sound level at 1m [dB(A)]		60	

* Intermittent duty: Let the pump stand still to cool down for at least one hour after two hours of operation.

Maximum working pressure

Description		Maximum working pressure [kPa]		
Rotor pressure range		Low	Medium	High
Hose type	NR Metering	400	800	1200*
	NR Transfer	400	800	—
	NBR	400	800	1200*
	F-NBR	400	800	1200*
	EPDM	400	800	1000
	CSM	400	800	1000

*In case of Bredel 20, high pressure is limited to 1000 kPa.

Materials

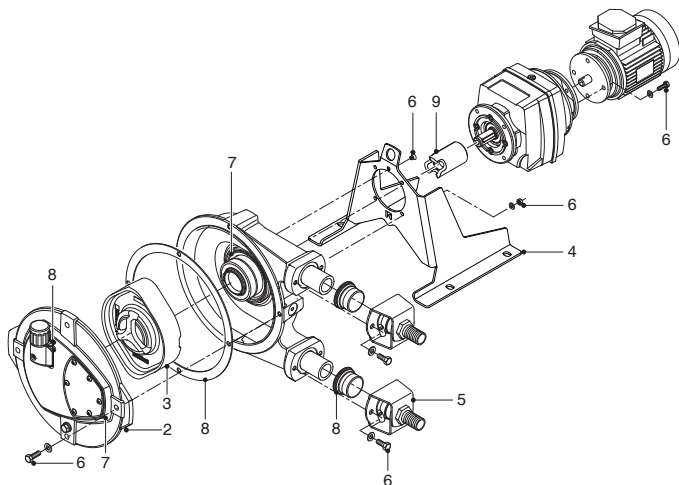

Pos.	Description	Material
1	Pump housing	Cast-iron
2	Cover	Cast-iron
3	Pump rotor	Cast-iron
4	Pump support	Galvanised steel (AISI 316 optional)
5	Brackets	AISI 316
6	Fasteners	AISI 316
7	Seals, gaskets	NBR
8	Seals, gaskets	EPDM
9	Coupling	Steel

Surface treatment

After surface preparation, one layer of two-component acrylate is used for surface protection. Standard colour is RAL 3011, other colours are optional. Contact your Bredel representative for advice on surface treatment.

All galvanised parts have an electrolytic zinc layer of 15 - 20 µm.

Lubricant table pump

Item	Bredel 10	Bredel 15, Bredel 20
Lubricant	Bredel Genuine Hose Lubricant	Bredel Genuine Hose Lubricant
Required quantity [litres]	0.25	0.5

Bredel Genuine Hose Lubricant is registered at NSF: NSF Registration No 123204; Category Code H1. Also refer to: www.nsf.org/certified-products-systems, and search for 'Bredel'.

Components		
Glycerol	(C ₃ H ₈ O ₃)	50-100% w/w
Glycol	(C ₃ H ₈ O ₂)	2.5-10% w/w
Water	(H ₂ O)	

Note: Contact your Bredel representative for advice if you require additional information with respect to the safety data sheet.



WARNING

It is the users responsibility to ensure the chemical compatibility of the fluid to be pumped with the lubricant in the pumphed. Obey the local Health and Safety regulations.

An alternative lubricant is available based on silicone. Also compatibility with this lubricant must be checked if applied. Refer to the chemical compatibility chart at www.wmftg.com/chemical or contact your Bredel representative for advice.

Weights

Description	Weight [kg]	
	Bredel 10	Bredel 15, Bredel 20
Pumphead complete*	12.2	22.0
Pump support	1.8	2.4
Hose	0.4	0.8
Lubricant	0.3	0.6
Pump cover (complete)	2.3	6.0
Coupling	0.4	0.4
Gearbox	28-GA52...	9.5
	28-GA53...	10
Electric motor	4.5	6.5

*Weight of a completely mounted pumphead (including hose, lubricant and supports).

Torque figures

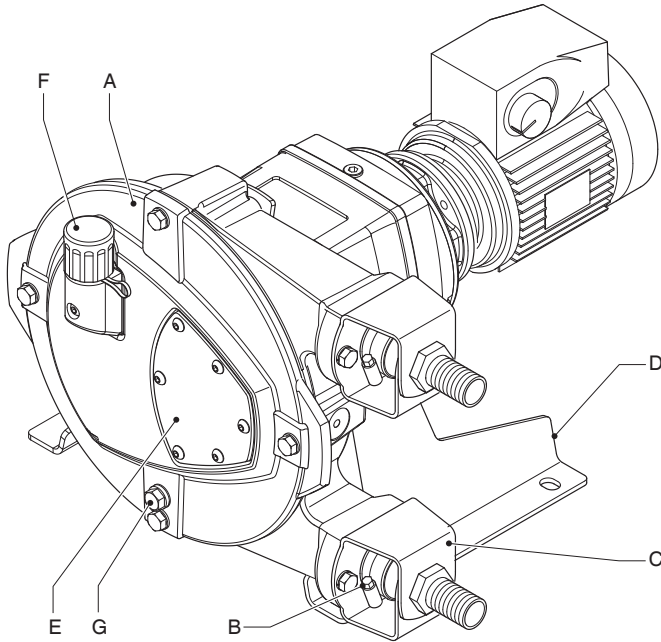

Pos.	Description	Torque [Nm]	
		Bredel 10	Bredel 15 - 20
A	Cover	10	25
B	Hose clamp	3	3
C	Bracket	10	25
D	Support	10	10
E	Inspection window	2	2
F	Breather	5	5
G	Drain plug	10	10

11.2 Gearbox

Type	Co-axial gearbox with helical gears.
Number of stages	Two or three.
Lubrication	Lubricated for life (refill is possible).
Mounting position	IM 2001 (IM B5) flanged gearbox with keyed shaft in horizontal position.
Motor adapter	Electric motor has been integrated in the gearbox housing, by which the smallest possible dimension is achieved.
Optional motor adapter	Adapters in conformance with IEC-B5 or NEMA TC.

Lubricant for gearbox

The standard gearbox is lubricated for life. If specific information about the lubricant is required, check the documentation that is supplied with the gearbox. Be aware that the type of lubricant depends on running conditions and ambient conditions. Special features might be required to keep the gearbox temperatures within limits. In case of doubt, contact your Bredel representative for advice.

11.3 Electric motor

The standard electric motor is an enclosed three-phase asynchronous motor, suitable for use in combination with a frequency inverter. As a standard, PTC temperature sensors are built-in.

Note: In case of doubt about the local applicable regulations for the drive connection, contact your Bredel representative.

Protection class	IP55/IK08
Insulation class	F
Increase in temperature	Within class B
Voltage/frequency	230/400 V - 3 phases - 50 Hz

11.4 Breidel Variable Frequency Drive (VFD) (optional)

The Breidel Variable Frequency Drive (VFD) has been preprogrammed and only needs to be connected to the mains.

RFI filter	Integrated RFI filter B (industrial applications).
Control	Manual control for setting the speed and the keys for starting forward, stop and starting reverse. More options are available.
Protection class	IP55
Mains power supply	Several types are available; the choice depends on the power and the local electricity grid: <ul style="list-style-type: none">• 200-240 V \pm 10%; 50/60 Hz \pm 5%; 1 ph• 200-240 V \pm 10%; 50/60 Hz \pm 5%; 3 ph• 400-480 V \pm 10%; 50/60 Hz \pm 5%; 3 ph

11.5 Parts list

Overview

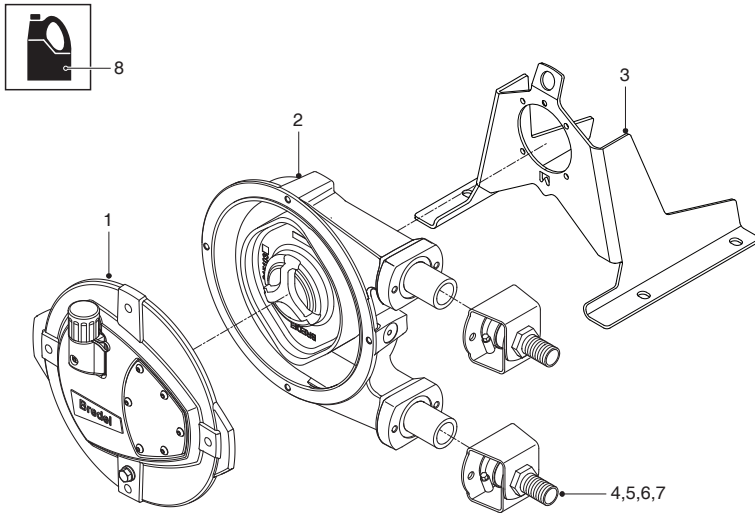

Pos.	Description
1	Refer to "Cover assembly" on the next page.
2	Refer to "Pumphead assembly" on page 72
3	Refer to "Support assembly" on page 76
4	Refer to "Barbed nipple assembly (PTFE/PVDF)" on page 78
5	Refer to "Barbed or threaded nipple assembly (stainless steel)" on page 80
6	Refer to "Flange assembly (1)" on page 83
7	Refer to "Flange assembly (2)" on page 85
8	Refer to "Lubricant" on page 89

Cover assembly

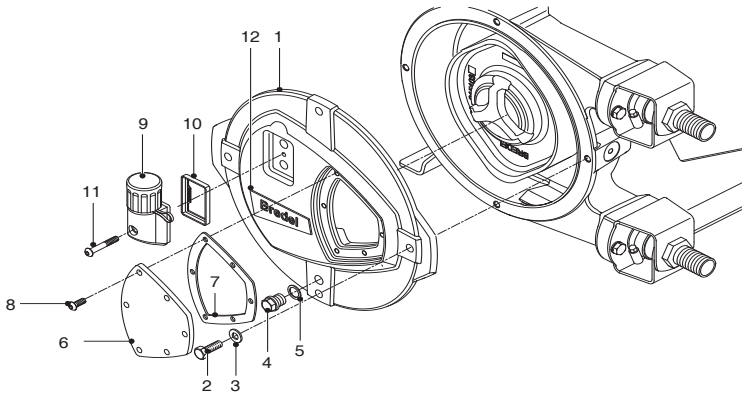

Bredel 10, 15 and 20

Pos.	Qty.	Description	Part number
1	1	Cover, Bredel 10	28-210102
		Cover, Bredel 15, Bredel 20	28-215102
2	2	Bolt, hex. head, Bredel 10	28-F504038
	4	Bolt, hex. head, Bredel 15, Bredel 20	28-F504055
3	2	Washer, Bredel 10	28-F523010
	4	Washer, Bredel 15, Bredel 20	28-F523012
4	1	Drain plug	28-F911502
5	1	Gasket	28-F342019
6	1	Inspection window, Bredel 10	28-210155
		Inspection window, Bredel 15, Bredel 20	28-215155
7	1	Gasket, Bredel 10	28-210156
		Gasket, Bredel 15, Bredel 20	28-215156

Pos.	Qty.	Description	Part number
8	3	Round head screw	28-F552535
9	1	Breather	28-1000051
10	1	Gasket	28-29056334-1
11	1	Round head screw	28-F552541
12	1	Sticker, Bredel 10	28-210238
		Sticker, Bredel 15	28-215238
		Sticker, Bredel 20	28-220238

Pumphead assembly

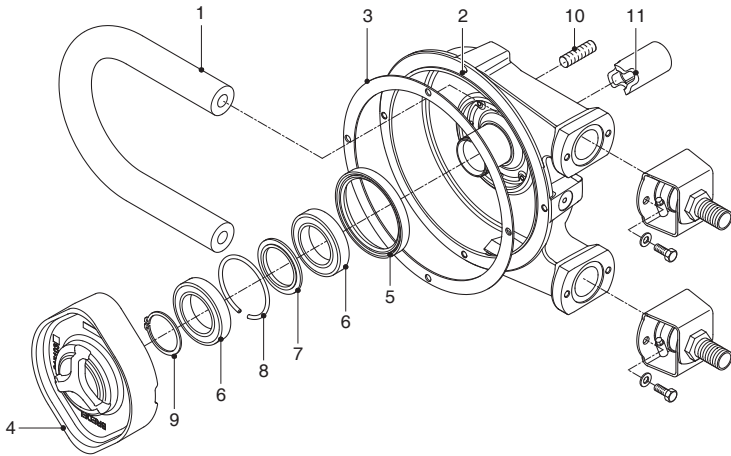

Bredel 10

Pos.	Qty.	Description	Part number
1	1	Hose NR Metering	28-1000053
		Hose NBR	28-010040
		Hose NBR Food	28-010061
		Hose F-NBR	28-010065
		Hose EPDM	28-010075
		Hose CSM	28-010070
2	1	Pump housing	28-210101
3	1	Gasket	28-210123
4	1	Rotor, low pressure	28-210103L
		Rotor, medium pressure	28-210103H
		Rotor, high pressure	28-210103X
5	1	Seal ring	28-S211811
6	2	Bearing	28-B141060
7	1	Spacer ring	28-29070201
8	1	Retaining ring	28-29080297
9	1	Circlip	28-F343043
10	4	Stud	28-F511001
11	1	Coupling, Ø 20 x 63 mm	28-29063255
		Coupling, Ø 20 x 68 mm	28-29068255
		Coupling, Ø 25 x 63 mm	28-29064255
		Coupling, Ø 25 x 68 mm	28-29069255

Bredel 15

Pos.	Qty.	Description	Part number
1	1	Hose NR Metering	28-1000055
		Hose NBR	28-015040
		Hose NBR Food	28-015061
		Hose F-NBR	28-015065
		Hose EPDM	28-015075
		Hose CSM	28-015070
2	1	Pump housing	28-215101
3	1	Gasket	28-215123
4	1	Rotor, low pressure	28-215103L
		Rotor, medium pressure	28-215103H
		Rotor, high pressure	28-215103X
5	1	Seal ring	28-S211811
6	2	Bearing	28-B141060
7	1	Spacer ring	28-29070201
8	1	Retaining ring	28-29080297
9	1	Circlip	28-F343043
10	4	Stud	28-F511001
11	1	Coupling, Ø 20 x 63 mm	28-29063255
		Coupling, Ø 20 x 68 mm	28-29068255
		Coupling, Ø 25 x 63 mm	28-29064255
		Coupling, Ø 25 x 68 mm	28-29069255

Bredel 20

Pos.	Qty.	Description	Part number
1	1	Hose NR Metering	28-1000057
		Hose NR Transfer	28-1007880
		Hose NBR	28-020040
		Hose NBR Food	28-020061
		Hose F-NBR	28-020065
		Hose EPDM	28-020075
		Hose CSM	28-020070
2	1	Pump housing	28-215101
3	1	Gasket	28-215123
4	1	Rotor, low pressure	28-220103L
		Rotor, medium pressure	28-220103H
		Rotor, high pressure	28-220103X
5	1	Seal ring	28-S211811
6	2	Bearing	28-B141060
7	1	Spacer ring	28-29070201
8	1	Retaining ring	28-29080297
9	1	Circlip	28-F343043
10	4	Stud	28-F511001
11	1	Coupling, Ø 20 x 63 mm	28-29063255
		Coupling, Ø 20 x 68 mm	28-29068255
		Coupling, Ø 25 x 63 mm	28-29064255
		Coupling, Ø 25 x 68 mm	28-29069255

Support assembly

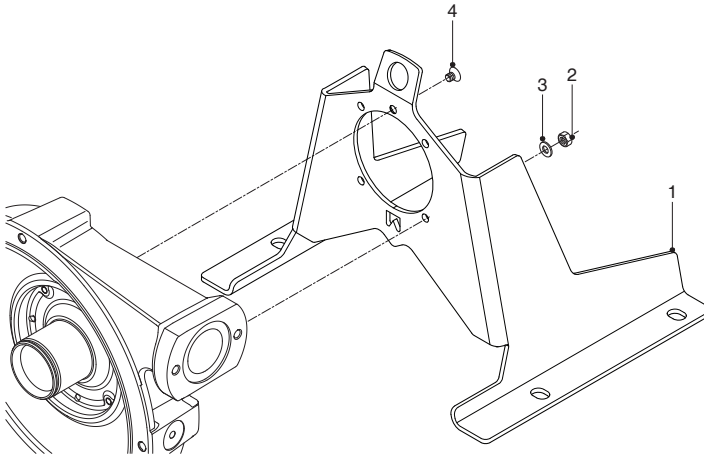

Bredel 10

Pos.	Qty.	Description	Part number
1	1	Pump support	28-210106
2	4	Nut, hex. head	28-F516010
3	4	Washer	28-F532008
4	1	Screw, countersunk head	28-F507040

Bredel 15

Pos.	Qty.	Description	Part number
1	1	Pump support	28-215106
2	4	Nut, hex. head	28-F516010
3	4	Washer	28-F532008
4	1	Screw, countersunk head	28-F507040

Bredel 20

Pos.	Qty.	Description	Part number
1	1	Pump support	28-215106
2	4	Nut, hex. head	28-F516010
3	4	Washer	28-F532008
4	1	Screw, countersunk head	28-F507040

Barbed nipple assembly (PTFE/PVDF)

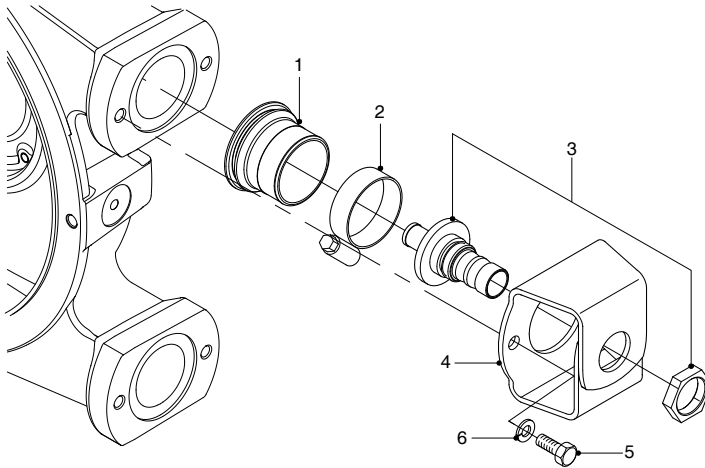

Bredel 10

Pos.	Qty.	Description	Part number
1	2	Rubber bush	28-210119
2	2	Hose clamp	28-C112507
3	2	Barbed nipple PTFE	28-210688010
		Barbed nipple PVDF	28-210690010
4	2	Bracket	28-210197
5	4	Bolt, Hex. head	28-F504036
6	4	Washer	28-F532008

Bredel 15

Pos.	Qty.	Description	Part number
1	2	Rubber bush	28-215119
2	2	Hose clamp	28-C112508
3	2	Barbed nipple PTFE	28-215688015
		Barbed nipple PVDF	28-215690015
4	2	Bracket	28-215197
5	4	Bolt, Hex. head	28-F504054
6	4	Washer	28-F532009

Bredel 20

Pos.	Qty.	Description	Part number
1	2	Rubber bush	28-215119
2	2	Hose clamp	28-C112508
3	2	Barbed nipple PTFE	28-215688020
		Barbed nipple PVDF	28-215690020
4	2	Bracket	28-215197
5	4	Bolt, Hex. head	28-F504054
6	4	Washer	28-F532009

Barbed or threaded nipple assembly (stainless steel)

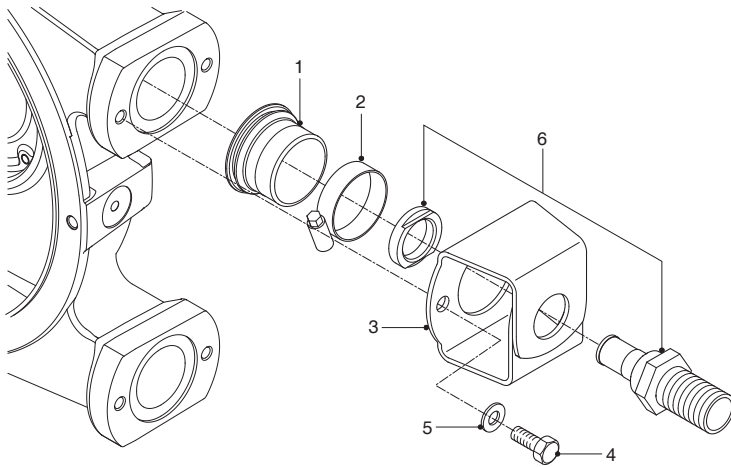

Bredel 10

Pos.	Qty.	Description	Part number
1	2	Rubber bush	28-210119
2	2	Hose clamp	28-C112507
3	2	Bracket	28-210197
4	4	Bolt, Hex. head	28-F504036
5	4	Washer	28-F532008
6	2	Threaded nipple (BSP) SS	28-210693010
		Barbed nipple SS	28-210686010
		Threaded nipple DIN 11851 SS	28-210702010
		Threaded nipple (NPT) PP	28-210696010
		Threaded nipple (NPT) PVC	28-210697010
		Threaded nipple (NPT) SS	28-210698010

Bredel 15

Pos.	Qty.	Description	Part number
1	2	Rubber bush	28-215119
2	2	Hose clamp	28-C112508
3	2	Bracket	28-215197
4	4	Bolt, Hex. head	28-F504054
5	4	Washer	28-F532009

Pos.	Qty.	Description	Part number
6	2	Threaded nipple (BSP) SS	28-215693015
		Barbed nipple SS	28-215686015
		Threaded nipple DIN 11851 SS	28-215702015
		Threaded nipple (NPT) PP	28-215696015
		Threaded nipple (NPT) PVC	28-215697015
		Threaded nipple (NPT) SS	28-215698015

Bredel 20

Pos.	Qty.	Description	Part number
1	2	Rubber bush	28-215119
2	2	Hose clamp	28-C112508
3	2	Bracket	28-215197
4	4	Bolt, Hex. head	28-F504054
5	4	Washer	28-F532009
6	2	Threaded nipple (BSP) SS	28-215693020
		Barbed nipple SS ^[1]	28-215686020
		Threaded nipple DIN 11851 SS	28-215702020
		Threaded nipple (NPT) PP	28-215696020
		Threaded nipple (NPT) PVC	28-215697020
		Threaded nipple (NPT) SS	28-215698020

1. The barbed nipple SS for the Bredel 20 has an outer diameter of 25 mm.

Flange assembly (1)

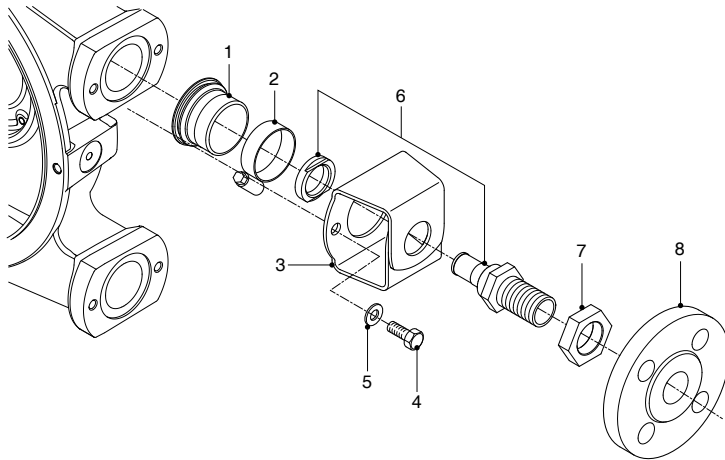

Bredel 10

Pos.	Qty.	Description	Part number
1	2	Rubber bush	28-210119
2	2	Hose clamp	28-C112507
3	2	Bracket	28-210197
4	4	Bolt, Hex. head	28-F504036
5	4	Washer	28-F532008
6	2	Threaded nipple (BSP) SS	28-210693010
7	2	Nut	28-F519003
8	2	Flange DIN SS	28-29094325
		Flange ASA SS	28-29088325

Bredel 15

Pos.	Qty.	Description	Part number
1	2	Rubber bush	28-215119
2	2	Hose clamp	28-C112508
3	2	Bracket	28-215197
4	4	Bolt, Hex. head	28-F504054
5	4	Washer	28-F532009
6	2	Threaded nipple (BSP) SS	28-215693015
7	2	Nut	28-F519004
8	2	Flange DIN SS	28-29105325
		Flange ASA SS	28-29098325

Bredel 20

Pos.	Qty.	Description	Part number
1	2	Rubber bush	28-215119
2	2	Hose clamp	28-C112508
3	2	Bracket	28-215197
4	4	Bolt, Hex. head	28-F504054
5	4	Washer	28-F532009
6	2	Threaded nipple (BSP) SS	28-215693020
7	2	Nut	28-F519004
8	2	Flange DIN SS	28-29105325
		Flange ASA SS	28-29098325

Flange assembly (2)

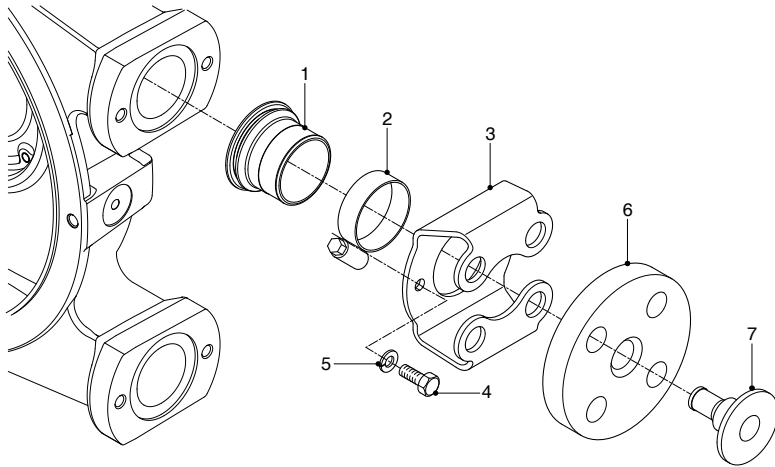

Bredel 10

Pos.	Qty.	Description	Part number
1	2	Rubber bush	28-210119
2	2	Hose clamp	28-C112507
3	2	Flange bracket	28-210197A
4	4	Bolt, Hex. head	28-F504036
5	4	Washer	28-F532008
6	2	Flange EN	28-210199
		Flange ANSI	28-210199A
7	2	Insert SS	28-210186
		Insert PP	28-210189

Bredel 15

Pos.	Qty.	Description	Part number
1	2	Rubber bush	28-215119
2	2	Hose clamp	28-C112508
3	2	Flange bracket	28-215197A
4	4	Bolt, Hex. head	28-F504054
5	4	Washer	28-F532009
6	2	Flange EN	28-210199
		Flange ANSI	28-215199A
7	2	Insert SS	28-215186
		Insert PP	28-215189

Bredel 20

Pos.	Qty.	Description	Part number
1	2	Rubber bush	28-215119
2	2	Hose clamp	28-C112508
3	2	Flange bracket	28-215197A
4	4	Bolt, Hex. head	28-F504054
5	4	Washer	28-F532009
6	2	Flange EN	28-215199
		Flange ANSI	28-215199A
7	2	Insert SS	28-220186
		Insert PP	28-220189

Revolution counter assembly

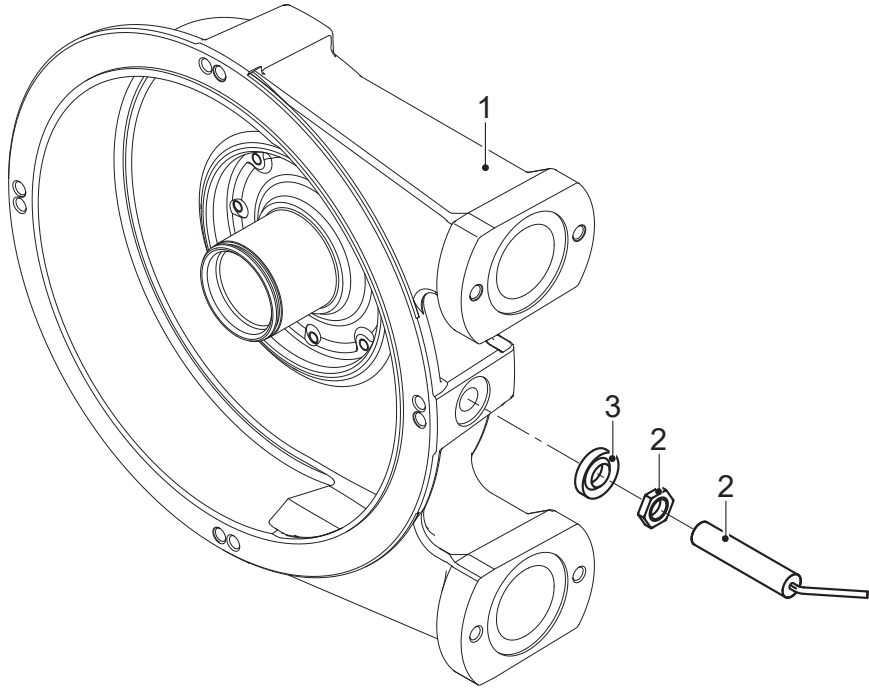

Bredel 10

Pos.	Qty.	Description	Part number
1	1	Pump housing	28-210101A
2	1	Revolution counter	28-29060367
3	1	Gasket ring	28-F724009

Bredel 15

Pos.	Qty.	Description	Part number
1	1	Pump housing	28-215101A
2	1	Revolution counter	28-29060367
3	1	Gasket ring	28-F724009

Bredel 20

Pos.	Qty.	Description	Part number
1	1	Pump housing	28-215101A
2	1	Revolution counter	28-29060367
3	1	Gasket ring	28-F724009

Lubricant

Pos.	Qty.	Description	Part number
-	1	0.5 l can Bredel Genuine Hose Lubricant	28-901143

Declaration of conformity

1. Manufacturer:
Watson-Marlow Bredel B.V.,
Sluisstraat 7, NL-7491 GA Delden, The Netherlands.

2. Object of the Declaration:
Product: Bredel hose pump series
Type designation: Bredel 10, Bredel 15, Bredel 20

3. This declaration of conformity is issued under the sole responsibility of the manufacturer.

4. The object of the declaration described above is in conformity with the relevant harmonisation legislation:
EU directive: Machinery Directive 2006/42/EC
UKCA directive: Supply of Machinery (Safety) Regulations 2008

5. The Object of this Declaration is in conformity with the applicable requirements of the following harmonised standards and technical specifications:
BS EN 809: 1998+A1:2009 Pumps and pump units for liquids - Common safety requirements
BS EN ISO 12100:2010 Safety of machinery - General principles for design - Risk assessment and risk reduction
BS EN ISO 60240-1: 2018 Safety of machinery - Electrical equipment of machines

On behalf of:
Watson-Marlow Bredel B.V.
Delden, 01 January 2023

*J. van den Heuvel, Managing Director, Watson-Marlow Bredel B.V.
Watson-Marlow Fluid Technology Solutions, telephone +31(0) 74 377 0000
A Spirax-Sarco Engineering plc company*

12 Safety form

Product Use and Decontamination Declaration

In compliance with the Health and Safety Regulations, the user is required to declare those substances that have been in contact with the item(s) you are returning to Watson-Marlow Bredel B.V. or any of its subsidiaries or distributors. Failure to do so will cause delays in servicing the item or in issuing a response. Therefore, **please complete this form** to make sure we have the information before receipt of the item(s) being returned. A completed copy must be attached to **the outside of the packaging** containing the item(s). You, the user, are responsible for cleaning and decontaminating the item(s) before returning them.

Please complete a separate Decontamination Certificate for each item returned.

RGK/KBR no......

1 Company
 Address
 Telephone Postal code
 Fax number

2 Product
 2.1 Serial Number
 2.2 Has the Product been used?
 YES NO
 If yes, please complete all the following paragraphs.
 If no, please complete paragraph 5 only

3 Details of substances pumped

3.1 Chemical Names
 a)
 b)
 c)
 d)

3.2 Precautions to be taken in handling these substances:
 a)
 b)
 c)
 d)

3.3 Action to be taken in the event of human contact:
 a)
 b)
 c)
 d)

3.4 Cleaning fluid to be used if residue of chemical is found during servicing;
 a)
 b)
 c)
 d)

4 I hereby confirm that the only substances(s) that the equipment specified has pumped or come into contact with are those named, that the information given is correct, and the carrier has been informed if the consignment is of a hazardous nature.

5 Signed
 Name
 Position
 Date

Note:
To assist us in our servicing please describe any fault condition you have witnessed.