

# Bredel 10



Hose Pumps

Bredel hose pumps (10-50)

## Features and benefits

- Dry running and self-priming
- Suction capability up to 9.5 mWC (374 inWC)
- No seals, ball-checks, diaphragms, glands, immersed rotors, stators or pistons to leak, clog, corrode or replace
- Handles abrasive slurries, corrosive acids, gaseous liquids
- No slippage, allowing true positive displacement for accurate and repeatable metering
- No ancillary equipment, check valves, sealing water flush systems or run-dry protection required
- Fully reversible to blow out suction and drain lines safely



## Bredel 10 performance

### Bredel 10

Required motor power kW (hp)

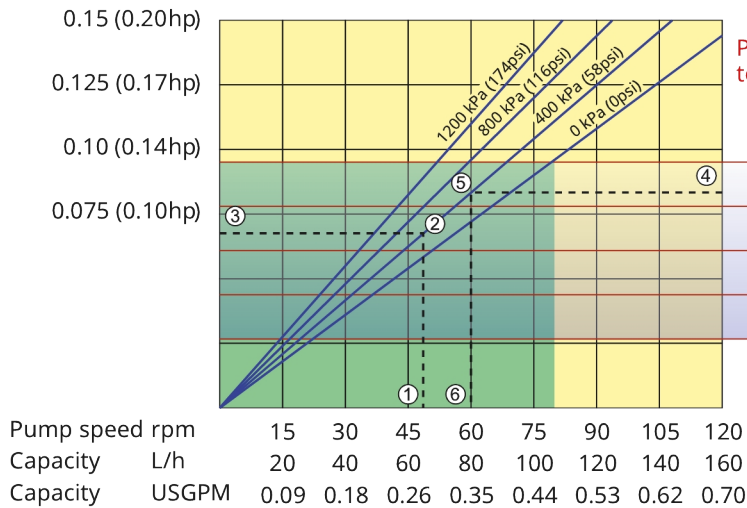

Note: The area of continuous operation diminishes with increased product temperatures. For product temperatures >40C, the area of continuous operation reduces to the corresponding red temperature line.

1. Flow required indicates pump speed
2. Calculated discharge pressure
3. Net motor power required
4. Product temperature
5. Calculated discharge pressure
6. Maximum recommended pump speed

- Continuous duty
- Intermittent duty

\* Maximum 3 hours operation followed by minimum 1 hour stop

## Technical specifications

	Bredel 10
Max. flow rate continuous	105 L/h
Max. flow rate continuous	28 USGPH
Max. flow rate intermittent	160 L/h
Max. flow rate intermittent	42 USGPH
Volume per revolution	0.022 L
Volume per revolution	0.0058 USG
Max. continuous operating speed	80 rpm
Max. intermittent operating speed	210 rpm
Max. operating pressure	12 bar
Max. operating pressure	174 psi
Max. inlet pressure	2 bar abs
Max. inlet pressure	30 psi abs
Max. suction capability	9.5 mWC
Max. suction capability	374 inWC
Suction capability (80% Flow rate)	9.5 mWC
Suction capability (80% Flow rate)	374 inWC
Operating temperature range	-20 to 45 °C
Operating temperature range	-4 to 113 °F
Fluid temperature range	-20 to 80 °C
Fluid temperature range	-4 to 176 °F
Min. starting torque	47 N m
Min. starting torque	416 in.lbs
Weight	30 kg
Weight	66 lbs
Hose lubricant required	0.25 L
Hose lubricant required	0.07 USG
Port configurations	Down, Left, Right, Up
Compatible hose materials	CSM, EPDM, F-NBR, NBR, NBR for food, NR-Metering, NR-Transfer
Flange assembly type	ANSI, DIN

Please consult your Bredel representative for lower or higher temperature operation.

Allowable ambient temperature is based on pump capabilities and may be further limited by gearbox ambient capabilities.

## Materials of construction

	Bredel 10
Hose material	CSM, EPDM, F-NBR, NBR, NBR for food, NR-Metering, NR-Transfer
Housing	Cast iron, ISO12944 category C4M
Rotor assembly	Cast iron, ISO12944 category C4M
Cover assembly	Cast iron, ISO12944 category C4M
Brackets and fasteners	Stainless steel 316
Support frame	Galvanized steel, Stainless steel 316
Hose clamps	Stainless steel 316
Coupling bush	Alloy steel
Seals	EPDM

## Bredel 10 dimensions

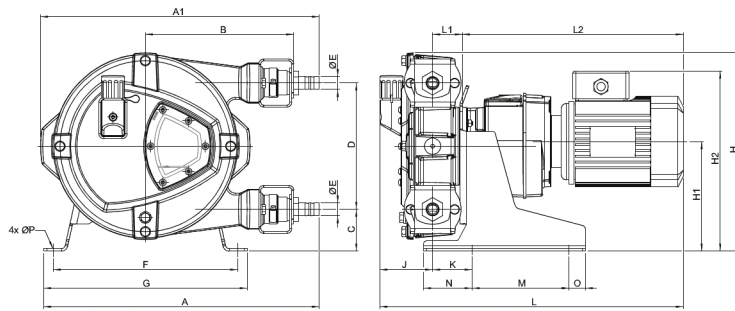

Type	A	A1	B	C	D	ØE	F	G	H	H1	H2max	J	K	Lmax	L1	L2max	M	N	O	ØP
Bredel 10 (mm)	337	311	171	62	116	16	235	265	225	127	254	78	51	501	46	378	150	65	25	12
Bredel 10 (inches)	13.3	12.2	6.7	2.44	4.6	16mm	9.3	10.4	8.9	5.0	10.0	3.1	2	19.7	1.8	14.9	5.9	2.6	1.0	12mm
Connector sizes									MNPT			EN DIN			JIS					
Bredel 10									0.5"			10mm			10mm					

Disclaimer: The information contained in this document is believed to be correct at the time of publication, but Watson-Marlow Bredel BV accepts no liability for any error it contains, and reserves the right to alter specifications without prior notice. All mentioned values in this document are values under controlled circumstances at our test bed. Actual flow rates achieved may vary because of changes in temperature, viscosity, inlet and discharge pressures and/or system configuration. APEX, DuCoNite, Bioprene and Bredel are registered trademarks.

[wmfts.com/global](http://wmfts.com/global)



23 November 2023