

Features and benefits

- Dry running and self-priming
- Suction capability up to 9.5 mWC (374 inWC)
- No seals, ball-checks, diaphragms, glands, immersed rotors, stators or pistons to leak, clog, corrode or replace
- Handles abrasive slurries, corrosive acids, gaseous liquids
- No slippage, allowing true positive displacement for accurate and repeatable metering
- No ancillary equipment, check valves, sealing water flush systems or run-dry protection required
- Fully reversible to blow out suction and drain lines safely

Bredel 20 performance

Bredel 20

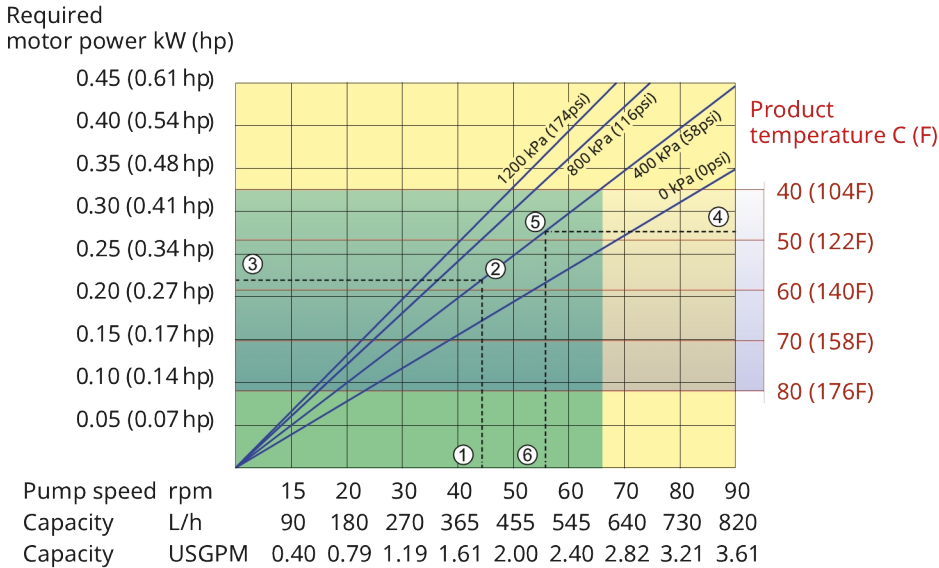

Note: The area of continuous operation diminishes with increased product temperatures. For product temperatures >40C, the area of continuous operation reduces to the corresponding red temperature line.

1. Flow required indicates pump speed
2. Calculated discharge pressure
3. Net motor power required
4. Product temperature
5. Calculated discharge pressure
6. Maximum recommended pump speed

- Continuous duty
- Intermittent duty

* Maximum 3 hours operation followed by minimum 1 hour stop

Technical specifications

	Bredel 20
Max. flow rate continuous	600 L/h
Max. flow rate continuous	158 USGPH
Max. flow rate intermittent	820 L/h
Max. flow rate intermittent	216 USGPH
Volume per revolution	0.152 L
Volume per revolution	0.0402 USG
Max. continuous operating speed	65 rpm
Max. intermittent operating speed	90 rpm
Max. operating pressure	10 bar
Max. operating pressure	145 psi
Max. inlet pressure	2 bar abs
Max. inlet pressure	30 psi abs
Max. suction capability	9.5 mWC
Max. suction capability	374 inWC
Suction capability (80% Flow rate)	9.5 mWC
Suction capability (80% Flow rate)	374 inWC
Operating temperature range	-20 to 45 °C
Operating temperature range	-4 to 113 °F
Fluid temperature range	-20 to 80 °C
Fluid temperature range	-4 to 176 °F
Min. starting torque	85 N m
Min. starting torque	752 in.lbs
Weight	45 kg
Weight	99 lbs
Hose lubricant required	0.5 L
Hose lubricant required	0.1 USG
Port configurations	Down, Left, Right, Up
Compatible hose materials	CSM, EPDM, F-NBR, NBR, NBR for food, NR-Metering, NR-Transfer
Flange assembly type	ANSI, DIN

Please consult your Bredel representative for lower or higher temperature operation.

Allowable ambient temperature is based on pump capabilities and may be further limited by gearbox ambient capabilities.

Materials of construction

	Bredel 20
Hose material	CSM, EPDM, F-NBR, NBR, NBR for food, NR Endurance, NR-Transfer
Housing	Cast iron, ISO12944 category C4M
Rotor assembly	Cast iron, ISO12944 category C4M
Cover assembly	Cast iron, ISO12944 category C4M
Brackets and fasteners	Stainless steel 316
Support frame	Galvanized steel, Stainless steel 316
Hose clamps	Stainless steel 316
Coupling bush	Alloy steel
Seals	EPDM

Bredel 20 dimensions

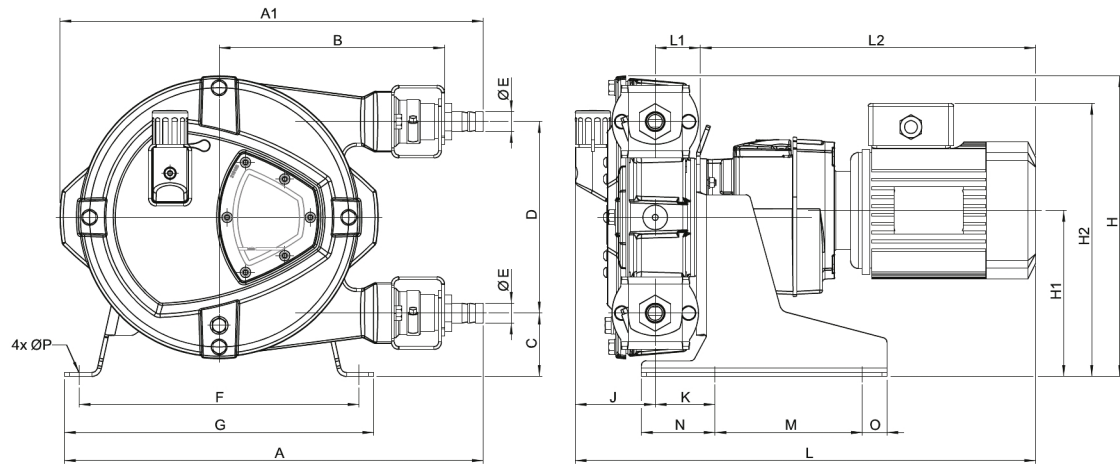

Type	A	A1	B	C	D	ØE	F	G	H	H1	H2max	J	K	Lmax	L1	L2max	M	N	O	ØP
Bredel 20 (mm)	427	431	230	63	195	20/25.5*	285	315	304	167	294	82	61	505	46	378	150	75	25	12
Bredel 20 (inches)	16.8	17.0	9.1	2.5	7.7	20mm/25.5mm*	11.2	12.4	12.0	6.6	11.6	3.2	2.4	19.9	1.8	14.9	5.9	3.0	1.0	12mm
Connector sizes								MNPT			EN DIN				JIS					
Bredel 20								0.75"			20mm				20mm					

Disclaimer: The information contained in this document is believed to be correct at the time of publication, but Watson-Marlow Bredel BV accepts no liability for any error it contains, and reserves the right to alter specifications without prior notice. All mentioned values in this document are values under controlled circumstances at our test bed. Actual flow rates achieved may vary because of changes in temperature, viscosity, inlet and discharge pressures and/or system configuration. APEX, DuCoNite, Bioprene and Bredel are registered trademarks.

wmfts.com/global



24 January 2024