

Bredel

Hose Pumps

BREDEL PUMP SERIES

Additional information on Bredel 25 and Bredel 32 pumps with bare shaft configuration

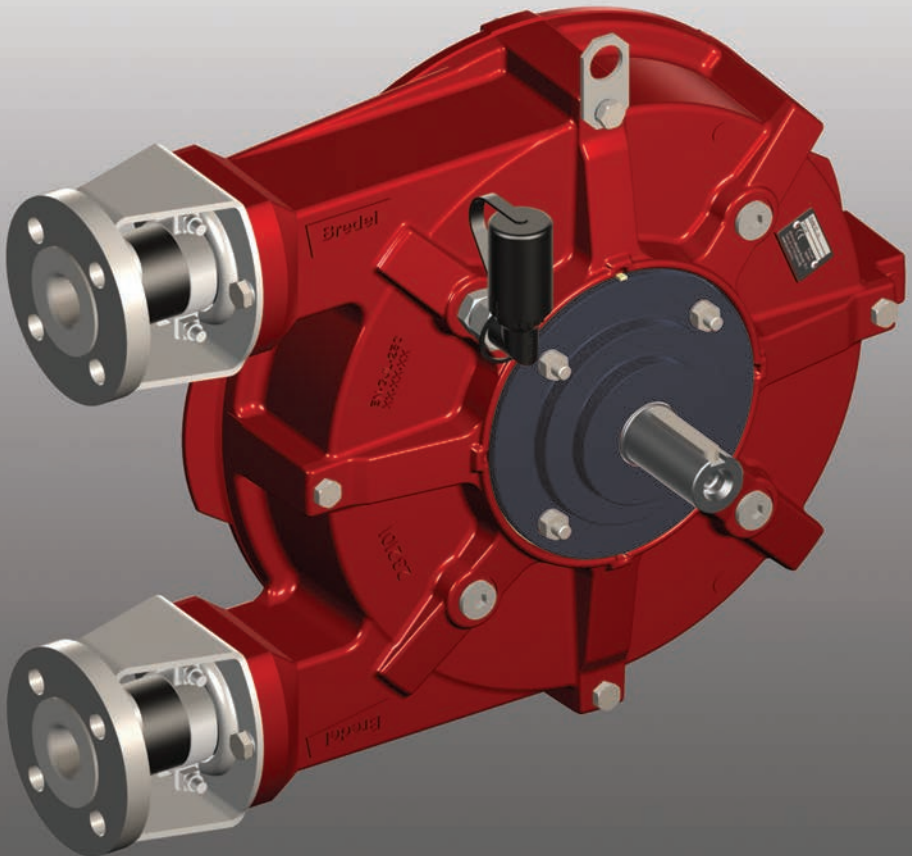

Additional information on Bredel 25 and Bredel 32 pumps with bare shaft configuration

Original Instructions



© 2017 Watson-Marlow Bredel B.V.

All rights reserved.

The information provided herein may not be reproduced and/or published in any form, by print, photoprint, microfilm or any other means whatsoever (electronically or mechanically) without the prior written authorisation of Watson-Marlow Bredel B.V.

The information provided can be changed without prior notification. Watson-Marlow Bredel B.V. or one of its representatives cannot be held liable for possible damage resulting from use of this manual. This is an extensive limitation of the liability which applies to all damage, inclusive of (without limitation) compensating, direct, indirect or consequential damage, loss of data, income or profit, loss or damage to possessions and claims of third parties.

Watson-Marlow Bredel B.V. provides the information in this manual "as is" and does not take any responsibility and does not give any guarantee on this manual or its content. Watson-Marlow Bredel B.V. rejects all responsibilities and guarantees. Furthermore, Watson-Marlow Bredel B.V. does not take responsibility for and does not guarantee that the information in this manual is accurate, complete or up to date.

Names, trade names, brands, etc. used by Watson-Marlow Bredel B.V. may not, as per the legislation concerning the protection of trade names, be considered as available.

CONTENTS**1 GENERAL**

1.1	<i>How to use this Manual</i>	2
1.2	<i>Service and Support</i>	2
1.3	<i>Used Products and the Environment</i>	3
1.4	<i>Symbols</i>	3
1.5	<i>Intended Use and Remarks on Safety</i>	3
1.6	<i>Warranty Conditions</i>	4

2 DESCRIPTION**3 INSTALLATION**

3.1	<i>Unpacking and Inspection</i>	6
3.2	<i>Installation</i>	6
3.2.1	<i>Mounting the Support Set and the Bare Shaft Kit to the Pumphead</i>	7
3.2.2	<i>Mounting and aligning the Drive</i>	9

4 MAINTENANCE

4.1	<i>Cleaning</i>	12
4.2	<i>Demounting the bare shaft kit</i>	12
4.3	<i>Disassembling the bare shaft kit</i>	14
4.4	<i>Assembling the bare shaft kit</i>	15
4.5	<i>Mounting the bare shaft kit onto the pump</i>	17

5 TROUBLESHOOTING**6 SPECIFICATIONS**

6.1	<i>Bredel 25 bare shaft set</i>	21
6.1.1	<i>Support set</i>	21
6.1.2	<i>Bare Shaft Kit</i>	22
6.2	<i>Bredel 32 bare shaft set</i>	23
6.2.1	<i>Support set</i>	23
6.2.2	<i>Bare Shaft Kit</i>	24
6.3	<i>Weights</i>	24
6.4	<i>Torque</i>	25
6.5	<i>Coupling</i>	25

SAFETY FORM

1 GENERAL

1.1 How to use this Manual

This manual is intended as a reference book for qualified users, enabling them to install, commission and maintain the bare shaft set as mentioned on the front cover. This manual is an addition to the pumphead manual, drive manual and gearbox manual. This manual does not replace any of these documents. The user should carefully read these documents before using this manual.

Documentation of components such as pumps, motors and inverters is normally not included in this manual. However, if additional documentation is supplied, you must follow the instructions in this additional documentation.

1.2 Service and Support

For information with respect to specific adjustments, installation, maintenance or repair jobs which fall beyond the scope of this manual, contact your Bredel representative. Make sure you have the following data at hand:

- Type and / or serial number of the hose pump.
- Description of the drive or gearbox.

You will find these data on the identification plates or stickers of the pumphead and the drive or gearbox.

1.3 Used Products and the Environment

Enquire with your local government about the possibilities for reuse or environment friendly processing of packaging materials, (contaminated) lubricant and oil.



ENVIRONMENT

Always observe the local rules and regulations with respect to processing (nonreusable) parts of the hose pump.

1.4 Symbols

In this manual the following symbols are used:



WARNING

Procedures which, if not carried out with the necessary care, may result in serious bodily harm.



CAUTION

Procedures which, if not carried out with the necessary care, may result in serious damage to the hose pump, the surrounding area or the environment.



Remarks, suggestions and advice.

1.5 Intended Use and Remarks on Safety

The bare shaft set is exclusively designed for supporting a Bredel pumphead and a drive. Every other use is not in conformance with the intended use. Refer to the manual of the pumphead for more information on safety and the intended use of the complete pump.

1.6 Warranty Conditions

Refer to the manual of the pumphead for warranty conditions. These conditions are applicable to the bare shaft set as well. Damaged parts of the bare shaft set that are returned to the manufacturer must be accompanied by a fully filled in and signed safety form that can be found in the manual of the pumphead.

2 DESCRIPTION

The bare shaft set, if delivered separately, consists of a support set (B) and a bare shaft kit (A). These two components are packed separately. If the set is delivered in a complete pump with pumphead and drive a flexible coupling (C) is included.

The support set consists of two frame halves, an adjustable drive support plate and a coupling guard.

The bare shaft kit consists of a shaft, a hub, a bearing and a seal. No fasteners are provided for mounting the drive or gearbox.

To align the pump and the drive use alignment jigs. The jigs are not included in the package.

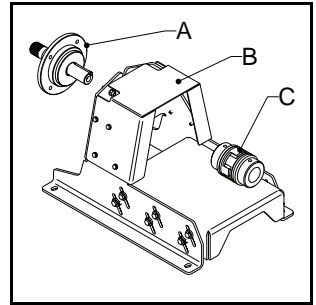

Destined for pump-head	Support set (A)	Bare shaft kit (B)	Coupling size (C)
Bredel 25	Bredel 25 Bareshaft Support Set	Bredel 25 Bareshaft Kit	38
Bredel 32	Bredel 32 Bareshaft Support Set	Bredel 32 Bareshaft Kit	38

3 INSTALLATION

3.1 Unpacking and Inspection

Follow the unpacking instructions on the packaging. Check that your delivery is correct and does not have transport damage. Report any damage immediately to your Bredel representative.

This chapter will treat the installation of the bare shaft set. Refer to the manual of the pumphead for installation and setup of the complete pump and the pipework.

3.2 Installation

**Caution**

The drive or gearbox and the pump must be aligned within the misalignment limits of the flexible coupling.



Carry out the alignment of the drive or gearbox and the pump at the pump's final operating position. If the support set has to be bolted to the floor this must be done first.

A movement of the complete pump will disturb the alignment due to elasticity of the construction.



If the bare shaft set is delivered as part of a complete pump, including pumphead and drive, a realignment must be done at the pump's final operating position.

3.2.1 Mounting the Support Set and the Bare Shaft Kit to the Pumphead

For mounting the kit to the pumphead, the pump must be disconnected from the process line and must be free of lubricants.

- Place the bare shaft kit (A) on a flat surface with the key end upward.
Press coupling half (B) onto the shaft end until shaft end face (C) and coupling surface (D) are at equal level.
Slightly fasten screw (E).
Prevent unnecessary axial load on the bearing.

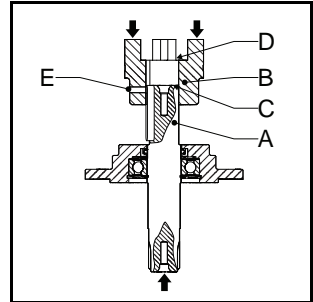

Alternative method of pressing the coupling half onto the shaft end is using a threaded rod screwed into the threaded hole in the shaft end, a disc with hole and a nut. Turning the nut will drive the coupling half onto the shaft.

This way the coupling half can be mounted after the placement of the bare shaft kit on the pumphead.

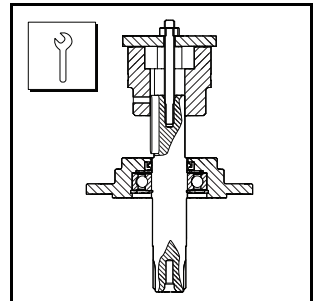

- Use a hoist to lift the pumphead and place the bare shaft kit (A) with the splined shaft end into the pump.
Make sure that the teeth correctly mesh with the teeth of the rotor inside the pump.

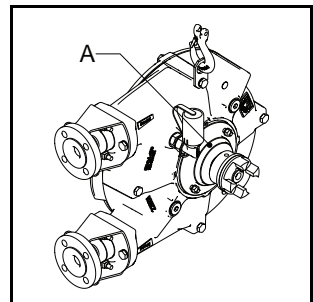

3. Use a hoist to place the pumphead (A) with the hub of the bare shaft kit against the support set (C). The coupling guard should be removed.
4. Place washers and nuts (B).

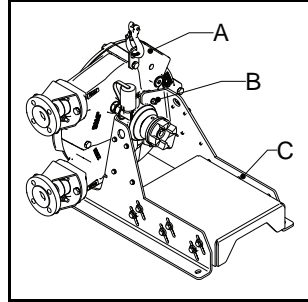

5. Tighten the nuts in at least two crosswise cycles. In the last cycle tighten them with the correct torque. See section 6.4.

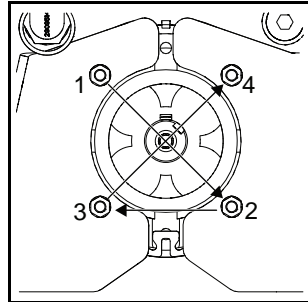

3.2.2 Mounting and aligning the Drive



Use a hoist to lift the heavy drive.



Mounting and aligning the drive must be done on the pump's final operation position. Moving the complete pump assembly after alignment will require re-alignment at the pump's final operation position.

1. Determine the correct height (h) of the centre of the bare shaft according to the surface on which the drive will be mounted. The bare shaft height must correspond with the height of the output shaft centre (of the drive that will be mounted).

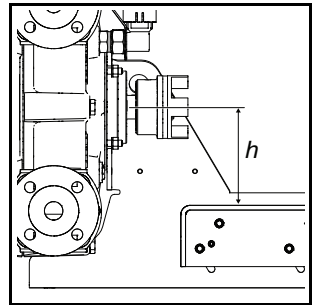

2. To correct the height loosen the 12 sets of fasteners (A).
Move plate (B) up or down to the correct position and slightly tighten the fasteners (A).
Check the height and repeat this step if necessary.
If the height is correct, tighten the fasteners (A) with the correct torque. See section 6.4.

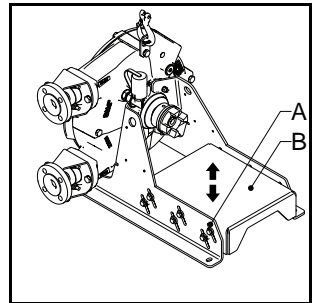

3. Place coupling half (B) on the output shaft of the drive and slightly fasten screw (C).
Make sure the shaft end has been shifted far enough into the coupling half but will not penetrate into the coupling spider (A).
4. Use a hoist to place the drive on the support set.
5. Make sure spider (A) is placed in one of the coupling halves.
6. Slide the drive toward the pumphead.
Make sure that the coupling halves (A) and the spider mesh correctly.

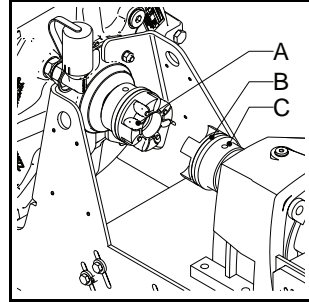

7. Use two alignment jigs (D) to check the alignment of the coupling halves in the vertical plane. Looking from aside both coupling halves (C) must touch the horizontal edge of the upper jig.
If necessary loosen the fasteners (A), readjust plate (B) and fasten the fasteners (A) to accomplish this. Use a hoist to lift the drive.
Axial, radial and angular displacement of the coupling halves must be minimised.

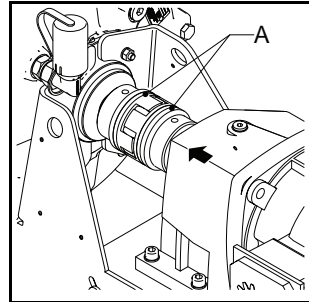

8. Each side plate of the support set has two pre-drilled holes (A).
Drill each hole through both plates.

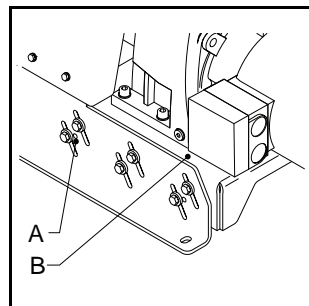
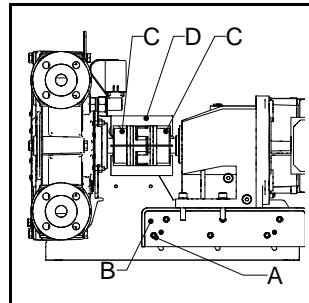

9. Drive a pin (A) into each drilled hole to fix the horizontal plate in the support set side plates.

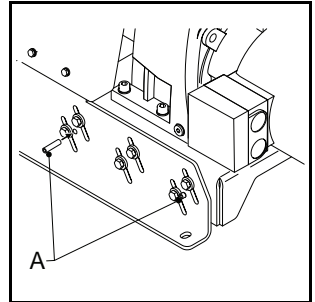

10. Use two alignment jigs (D) to check the alignment of the coupling halves in the horizontal plane. Looking from above both coupling halves (C) must touch the edge of both jigs.

If necessary move the drive (E) over the plate (B) to accomplish this.

Axial, radial and angular displacement of the coupling halves must be minimised.

11. Mark the holes (A) for fixing the drive on the plate of the support set using a punch and a hammer, or a felt-tip pen.
12. Remove the alignment jigs and use a hoist to remove the drive.
13. Drill holes, with the correct diameter, in the horizontal plate (B) at the marked places. See section 6.4.
14. Remount the drive and slide it toward the pumphead so that the coupling halves mesh.
15. Fix the drive to the horizontal plate with fasteners (C) (washers, bolts and nuts). Do not tighten the fasteners yet.
16. Repeat step 10. (alignment in a horizontal plane)
Tighten the fasteners (C) and the screws of the coupling halves with the correct torque. See section 6.4.
17. Place the coupling guard (A).
Tighten the fasteners (B) with the correct torque. See section 6.4.

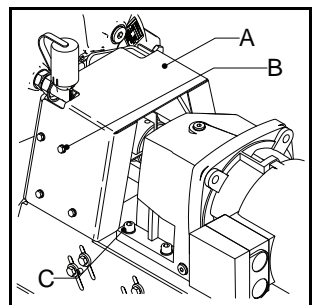
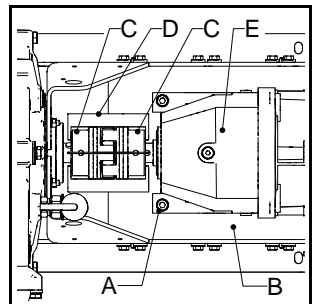

4 MAINTENANCE

4.1 Cleaning

**Warning**

When cleaning the pump do not use a high-pressure spraying pistol. This might damage the seal and the bearing.

4.2 Demounting the bare shaft kit



When the bare shaft kit is demounted the pumphead will come loose from the support set. The pumphead must be supported in some way, or the pumphead has to be tipped to the front. In the latter case piping has to be disconnected and lubricant has to be removed first. In this manual it is assumed that the pumphead is lifted with a hoist and remains fixed to the hoist.

1. Isolate the drive from the electrical supply.
2. Close any shut-off valves in the suction and discharge lines and disconnect these lines. Refer to the manual of the pump.
3. Place the hook of the hoist in the lifting strip (A). Hoist the pump, so that the pump is secure when it comes loose from the bare shaft kit.

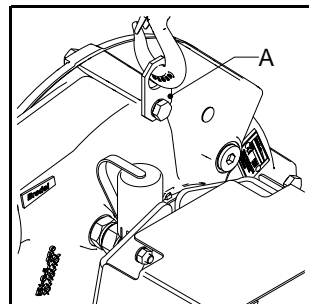

4. Remove the bolts (B) to remove the coupling guard (A).

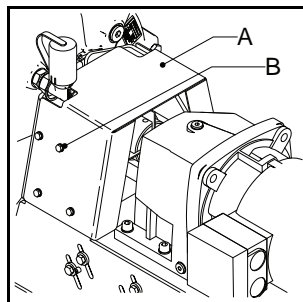

5. Loosen the fasteners (A) to demount the pumphead from the support set.
Move the pumphead away from the support set.

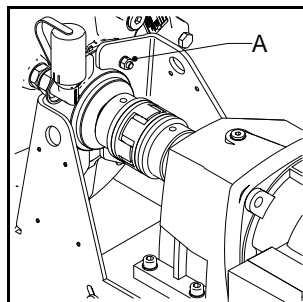

6. Demount the bare shaft kit (A).

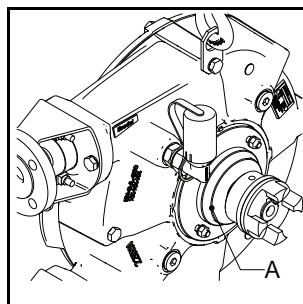

4.3 Disassembling the bare shaft kit

1. Remove coupling half (B) from the shaft by loosening screw (A). Use a suitable pulling device.
Do not put axial load on the bearing if it is to be reused.

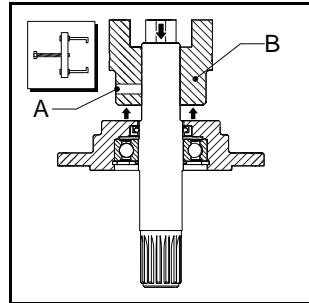

2. Remove retaining ring (A).
3. Remove key (B).

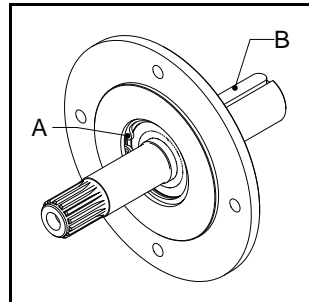

4. Push shaft (A) out of hub (B). Use a suitable pulling device.

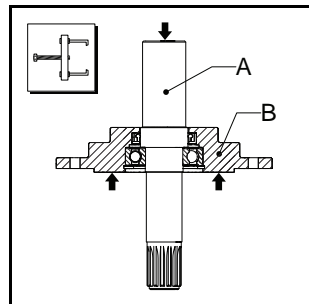

5. Remove the retaining ring (B).
6. Remove bearing (C) from shaft (A). Use a suitable pulling device.

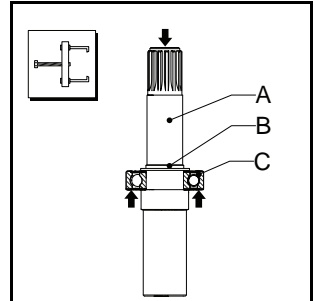

7. Remove seal (A) from hub (B). If the seal is to be replaced pliers can be used.

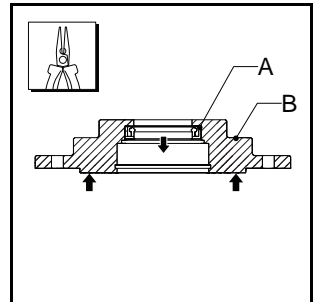

4.4 Assembling the bare shaft kit

Check the bearing and the seal before reuse. If necessary use a new bearing and a new seal.

1. Place the hub (B) on a flat surface, with the bearing side upward. Clean the contact surfaces (A) for bearing and seal, and put some transmission oil on these surfaces.

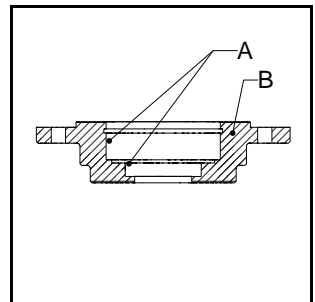

2. Use a suitable tool to press seal (A) into the hub (B) until it hits the collar. Keep the closed side of the seal upward.
3. Put an excessive amount of grease on the lip of the seal.

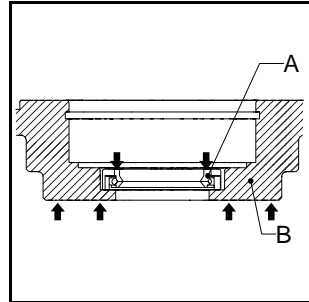

4. Clean the contact surfaces (A) for bearing and seal on the shaft (B). Put some grease on these surfaces.

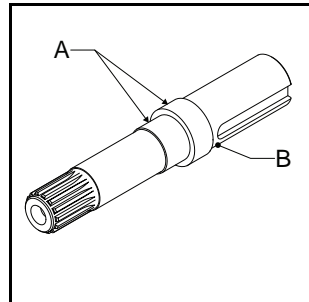

5. Place shaft (D) on a flat surface with the key end downward. Press bearing (B) on the shaft with a suitable tool until it touches the rim (C). Apply pressure on the inner ring only to avoid damage. Place the inner retaining ring (A) to lock the bearing.

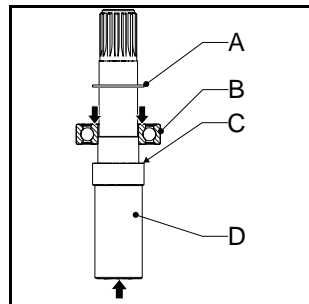

6. Place the hub (B), with the bearing side upward, on a flat surface with a hole. Place shaft (C), with the key end pointing down, into the hub (B). Press bearing (A), with a suitable tool, into the hub until it touches the bearing rim. Apply pressure on the outer ring only to avoid damage.

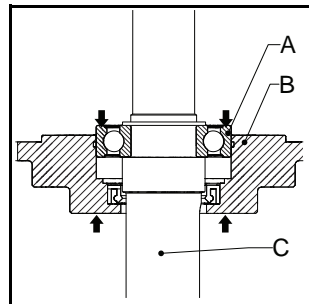

7. Place key (B) onto the shaft.
8. Place retaining ring (A) into the hub.
9. Mount a coupling half on the shaft end. See section 3.2.1 step 1.

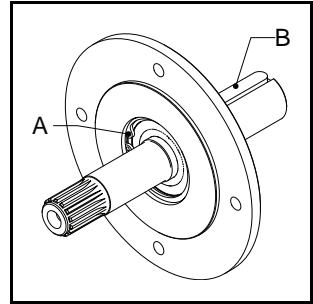

4.5 Mounting the bare shaft kit onto the pump

For this procedure the pumphead should still be hanging in the hoist while the support set is still demounted. One coupling half is still mounted on the drive shaft end.

If necessary apply a new spider for the flexible coupling.

1. Place the bare shaft kit (A) with the splined shaft end into the pump and assure that the teeth correctly mesh with the holes in the rotor inside the pump.

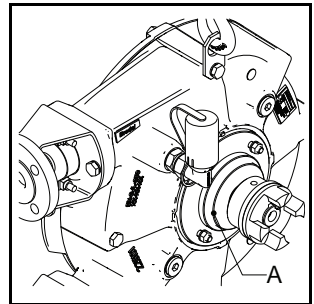

2. Place the pumphead on the support set with drive.
Make sure the coupling teeth and spider (B) mesh correctly with the opposite coupling half on the drive.
3. Place washers.
Place nuts (A).

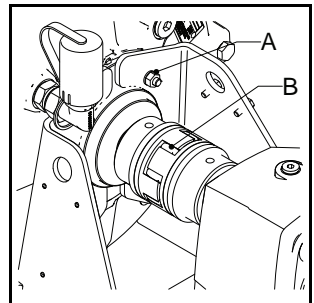

4. Tighten the bolt or nuts in at least two crosswise cycles. In the last cycle tighten them with the correct torque. See section 6.4.

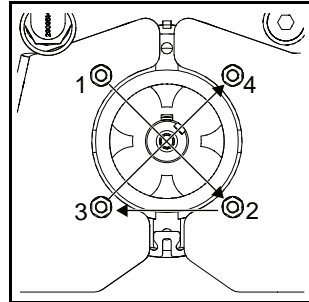

5. Tighten the screw (A) to fix the coupling half on the bare shaft end.
6. Check the alignment of the coupling halves with the alignment jigs (See section 3.2.2).

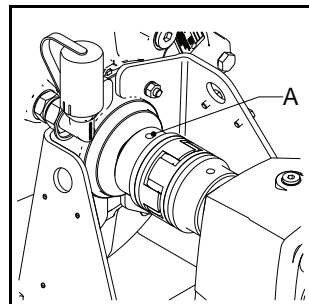

7. Install the coupling guard (A) with the bolts (B).
8. Connect the suction and discharge lines and open any shut-off valves in these lines. Refer to the manual of the pump.
9. Connect the drive to the electric supply.

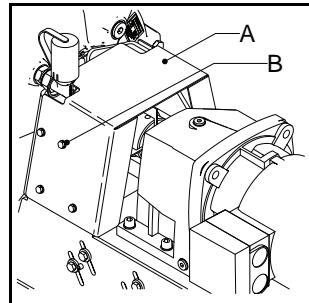

5 TROUBLESHOOTING

**WARNING**

Disconnect and lock the power supply to the pump drive before any work is carried out.

In case the motor is fitted with a frequency controller and has a single phase power supply, wait at least two minutes to make sure that the capacitors have discharged.

The main problem cause related to the bare shaft set is poor alignment of the coupling halves. This will cause the pumphead to wobble while it is driven, even without discharge pressure or piping connected.

With proper alignment the pump will show some movement caused by the drive torque and the reaction force from the rotor. This movement will be within the coupling alignment tolerances as given in section 6.5

Poor misalignment will shorten the lifetime of the bearing in the bare shaft kit, the bearing(s) in the gearbox and the spider in the flexible coupling. Follow the checklist if problems or doubts exist. If no relation with alignment can be found for any problem refer to the chapter Troubleshooting in the pump's manual.

Problem	Possible cause	Correction
Cyclic movement of the pumphead.	Misalignment of pumphead and drive.	Check the alignment of pumphead and drive. See chapter 3. Check the fixation of the pumphead and the drive to the support set. Check the fixation of the support set components.
Rattling or squeaking noise near the pumphead.	Damaged bare shaft kit bearing	Check the alignment. See above. Check the bearing and the seal and replace if necessary. See chapter 4.
Rattling or squeaking noise near the gearbox.	Damaged gearbox bearing(s)	Check the alignment. See above. Check the condition of the gearbox. Refer to the documentation of the gearbox.
Spider particles on the drive support plate	Damaged spider in the flexible coupling	Check the alignment. See above. Replace the spider. Check the condition of the coupling halves and replace these if necessary.

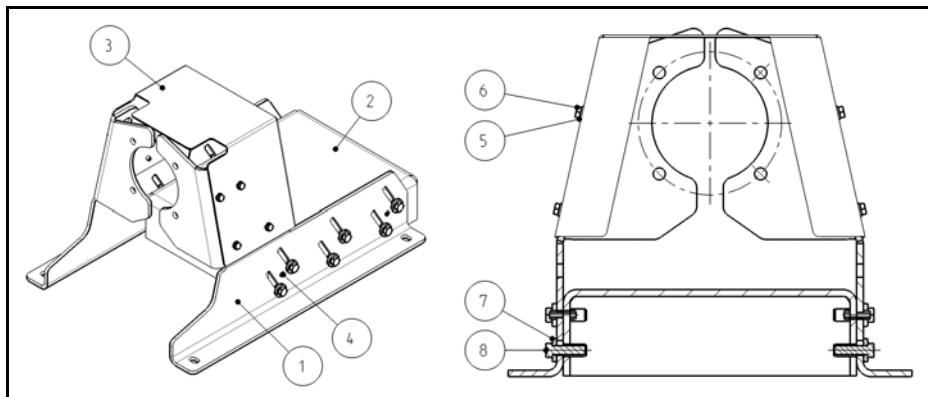
6 SPECIFICATIONS
6.1 Bredel 25 bare shaft set
6.1.1 Support set

Pos.	Qty.	Description	Size	Material
1	1	Pump support		steel
2	1	Gearbox support		steel
3	1	Coupling guard		steel
4	4	Pin	ISO 8750 - 8 x 24	steel
5	8	Plain washer	M6	steel
6	8	Hexagonal bolt	M6 x 16	steel
7	12	Thick flat washer	M8	steel
8	12	Hexagonal head screw	M8 x 30	steel

6.1.2 Bare Shaft Kit

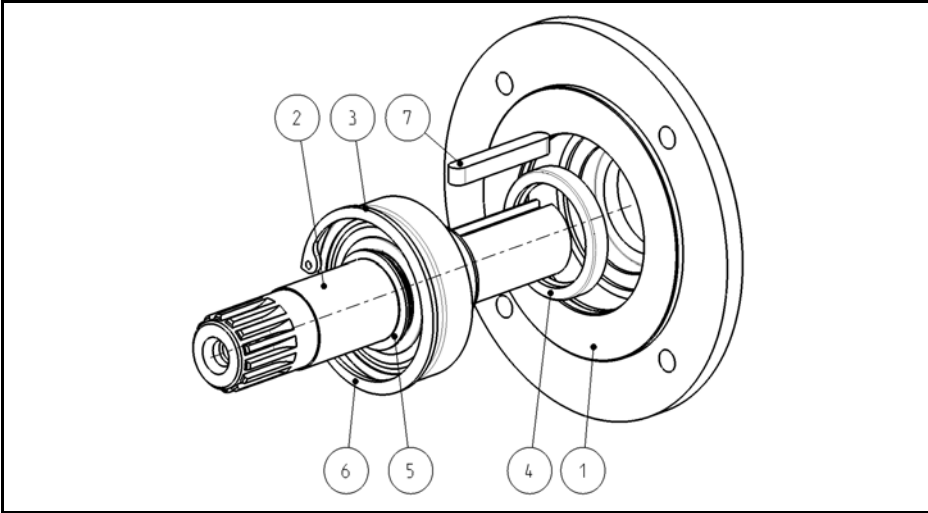

Pos.	Qty.	Description	Size	Material
1	1	Hub		steel
2	1	Shaft		steel
3	1	Bearing	6207-2RS1	steel
4	1	Radial shaft seal	CR 40 x 52 x 8 - HMS5	NBR
5	1	Retaining ring	DIN 471 - A35	steel
6	1	Retaining ring	DIN 472 - 72	steel
7	1	Parallel key	DIN 6885A - 8 x 7 x 56	steel

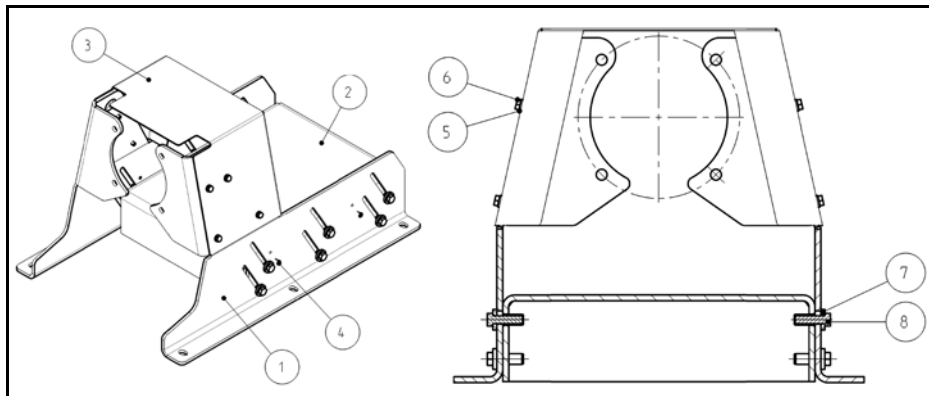
6.2 Bredel 32 bare shaft set
6.2.1 Support set

Pos.	Qty.	Description	Size	Material
1	1	Pump support		steel
2	1	Gearbox support		steel
3	1	Coupling guard		steel
4	4	Pin	ISO 8750 - 8 x 24	steel
5	8	Plain washer	M6	steel
6	8	Hexagonal Bolt	M6 x 16	steel
7	12	Thick flat washer	M8	steel
8	12	Hexagonal head screw	M8 x 30	steel

6.2.2 Bare Shaft Kit

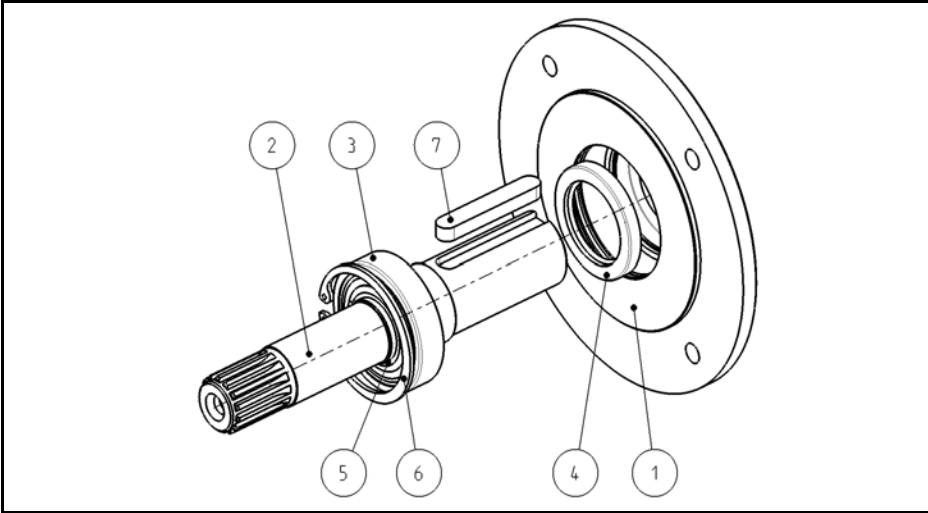

Pos.	Qty.	Description	Size	Material
1	1	Hub		steel
2	1	Shaft		steel
3	1	Bearing	6207-2RS1	steel
4	1	Radial shaft seal	CR 43 x 62 x 8 - HMS5	NBR
5	1	Retaining Ring	DIN 471 - A35	steel
6	1	Retaining Ring	DIN 472 - 72 x 2.5	steel
7	1	Parallel key	DIN 6885A - 12 x 8 x 70	steel

6.3 Weights

Bare Shaft Set	Weights [kg]		
	Support set	Bare shaft kit	Coupling*
Bredel 25	19.0	3.8	2.7
Bredel 32	26.1	6.3	2.7

*Coupling weight is an approximation. The actual weight depends on the used coupling type.

6.4 Torque

Following table shows general tightening torques for steel fasteners with metric thread.

Metric thread size	Torque [Nm]	Drill diameter [mm]
M5	6	6
M6	10	7
M8	25	9
M10	50	11
M12	85	13
M16	210	18
M20	400	22

6.5 Coupling

These are specifications of the flexible couplings which are delivered as part of a complete pump based on the bare shaft solution.

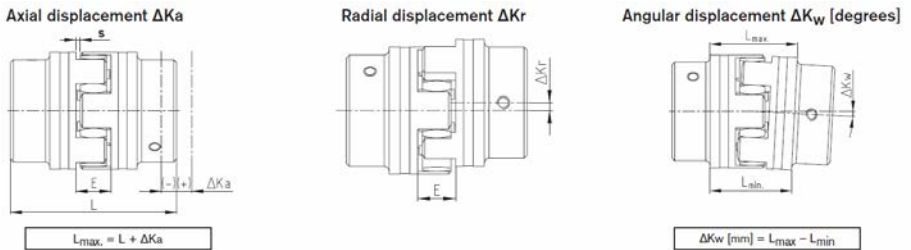

Coupling size	L [mm]	E [mm]	s [mm]	Maximum displacements			Rated torque [Nm]
				ΔKa [mm]	ΔKr [mm]	ΔKw [degrees]	
38	114	24	3	-0.7 +1.8	0.28	1.0	190

SAFETY FORM

**WARNING**

A complaint will only be handled by Bredel if this Safety Form is fully completed and digitally send to Bredel before shipment is activated. A hardcopy of this form is to be attached to the outside of the packaging including MSDS sheet or similar safety information sheet if applicable for each item returned.

Product Use and Decontamination Declaration**TS16-002 rev. 0**

In compliance with our **Health & Safety Regulations**, the user is required to declare any substances that have been in contact with the item(s) being returned to Watson-Marlow Bredel B.V. or any of its subsidiaries or distributors. Not following these requirements may lead to delays in service and/ or response time. Full completion of this form assures we are provided with necessary information before receipt of the item(s) being returned. A hardcopy of the completed form must be attached to **the outside of the packaging** containing the item(s). The sender of the item(s) is responsible for cleaning and decontaminating of the item(s) before returning them in such way that it is safe for the receiver to open the packaging and handle the item(s).

Complaint number:

1. Company:
 Address: Postal code:
 Contact person: Email address:
 Telephone: Fax number:

2. Product:

2.1 Serial Number:

2.2 Has the Product been used?

Yes (Go to section 3)

No (Go to section 5)

3. Details of substances pumped

3.1 Chemicals names:

(a)

(b)

(c)

(d)

3.2 Precautions to be taken in handling these substances:

(a)

(b)

(c)

(d)

3.3 Actions to be taken in event of human contact:

(a)

(b)

(c)

(d)

3.4 Cleaning fluid to be used if residue of chemical is found during service:

(a)

(b)

(c)

(d)

4. I hereby confirm that the only substance(s) that the equipment specified has pumped or come into contact with those named, that the information given is correct and the carrier has been informed if the consignment is of a hazardous nature.

5. Signed:

Name:

Position:

Date:

Note:

To assist us in our service, please describe any fault condition you have witnessed.

.....

.....

.....

.....

Quantity of sheets attached:

Watson-Marlow Bredel B.V.
P.O. Box 47
NL-7490 AA Delden
The Netherlands
Telephone: +31 (0)74 3770000
Fax: +31 (0)74 3761175
E-mail: Bredel@wmftg.com
Internet: www.wmftg.com



© 2017 Watson-Marlow Bredel B.V.

Bredel

Hose Pumps

Watson-Marlow Bredel B.V.
P.O. Box 47
NL-7490 AA Delden
The Netherlands

T +31 (0)74 3770000
F +31 (0)74 3761175
E bredel@wmftg.com

www.bredel.com



Watson-Marlow Alitea Bredel Flexicon MasoSine BioPure Asepto FlowSmart Aflex



Watson-Marlow online

Our engineers around the world can help you choose the perfect pump and tubing for your needs.

More information? Our brochures are on our website – www.wmftg.com



You can find the most recent version of the manual and translations at www.wmftg.com/literature. On this page, select 'Bredel', 'Manual' and the required language

With your phone or tablet you can scan the QR code. This will forward you directly to the website where you can select the manual

You can also find translations on the disc inserted in the front cover

Watson-Marlow... Innovation in Full Flow

Tel: +31 74 3770000
www.bredel.com

Part of the
Watson-Marlow Fluid Technology Group
A Spirax-Sarco Engineering Company



DuCoNite® and Watson-Marlow Bredel are registered trademarks.

The information contained in this document is believed to be correct at the time of publication, but Watson-Marlow Bredel B.V. accepts no liability for any error it contains, and reserves the right to alter specifications without prior notice. All mentioned values in this document are values under controlled circumstances at our test bed. Actual flow rates achieved may vary because of changes in temperature, viscosity, inlet and discharge pressures and / or system configuration. DuCoNite®, Marprene®