

DuCoNite32

Bredel DuCoNite® pumps

Bredel

Hose Pumps

Features and benefits

- Dry running and self-priming
- Suction capability up to 9.5 mWC (374 inWC)
- Simple hose change decreases cost of ownership, downtime and need for parts inventory
- “Beyond the hose” protection against common water and waste water treatment chemicals
- Paint-free pump housing perfect for wash-down in the food industry
- No slippage, allowing true positive displacement for accurate and repeatable metering
- No ancillary equipment, check valves, sealing water flush systems or run-dry protection required
- Fully reversible to blow out suction and drain lines safely



DuCoNite32 performance

DuCoNite 32

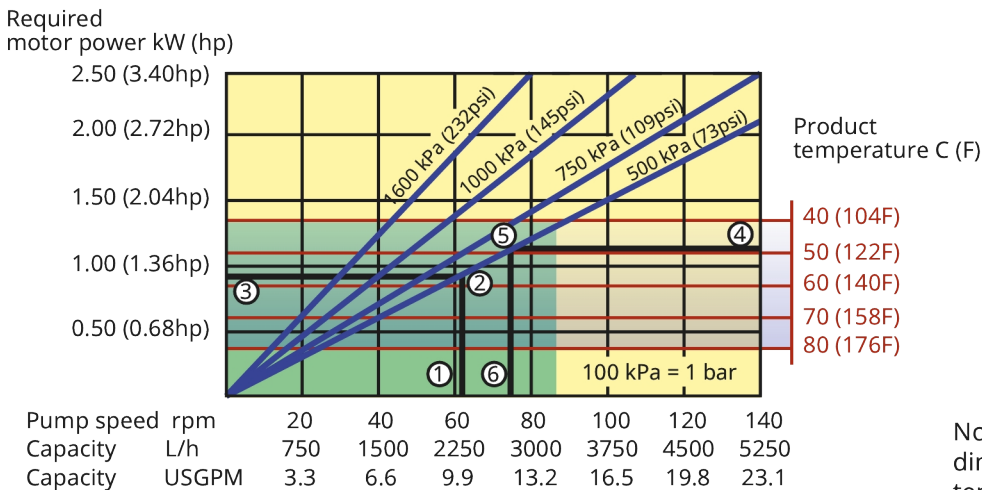

Note: The area of continuous operation diminishes with increased product temperatures. For product temperatures >40C, the area of continuous operation reduces to the corresponding red temperature line.

1. Flow required indicates pump speed
2. Calculated discharge pressure
3. Net motor power required
4. Product temperature
5. Calculated discharge pressure
6. Maximum recommended pump speed

- Continuous duty
- Intermittent duty

* Maximum 3 hours operation followed by minimum 1 hour stop

Technical specifications

	DuCoNite32
Max. flow rate continuous	3200 L/h
Max. flow rate continuous	844 USGPH
Max. flow rate intermittent	5250 L/h
Max. flow rate intermittent	1385 USGPH
Volume per revolution	0.625 L
Volume per revolution	0.165 USG
Max. continuous operating speed	86 rpm
Max. intermittent operating speed	140 rpm
Max. operating pressure	16 bar
Max. operating pressure	232 psi
Suction pressure	0.05 bar abs
Suction pressure	0.73 psi abs
Max. inlet pressure	3 bar abs
Max. inlet pressure	44 psi abs
Max. suction capability	9.5 mWC
Max. suction capability	374 inWC
Operating temperature range	-20 to 45 °C
Operating temperature range	-4 to 113 °F
Fluid temperature range	-20 to 80 °C
Fluid temperature range	-4 to 176 °F
Min. starting torque	210 N m
Min. starting torque	1859 in.lbs
Weight	130 kg
Weight	287 lbs
Hose lubricant required	4.5 L
Hose lubricant required	1.19 USG
Port configurations	Down, Left, Right, Up
Compatible hose materials	CSM, EPDM, F-NBR, NBR, NBR for food, NR, NR-Metering, NR-Transfer
Flange assembly type	ANSI, DIN

Please consult your Bredel representative for lower or higher temperature operation.

Allowable ambient temperature is based on pump capabilities and may be further limited by gearbox ambient capabilities.

Materials of construction

	DuCoNite32
Hose material	CSM, EPDM, F-NBR, Natural rubber (NR), NBR, NBR for food, NR-Metering, NR-Transfer
Housing	Cast iron with DuCoNite surface treatment
Rotor assembly	Cast iron with DuCoNite surface treatment
Cover assembly	Cast iron with DuCoNite surface treatment
Brackets and fasteners	Stainless steel 316
Support frame	Stainless steel 316
Hose clamps	Stainless steel 316
Seals	EPDM, Viton®

DuCoNite32 dimensions

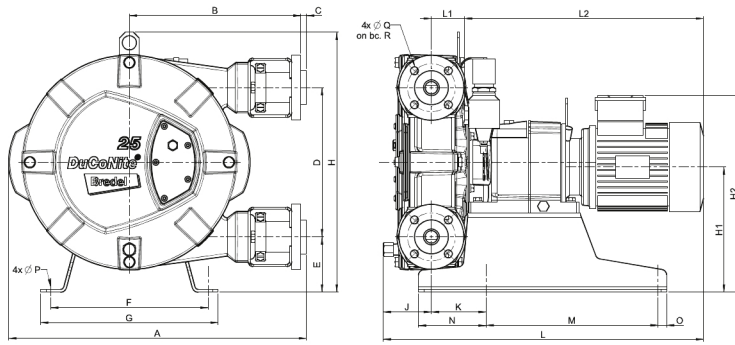

Type	A	B	C	D	E	F	G	H	H1	H2max	J	K	Lmax	L1	L2max	M	N	O	ØP	ØQ	R
DuCoNite 32 (mm)	631	375	2.5	330	105	324	360	538	260	402	72	93	684	68	544	370	120	20	12	18	100
DuCoNite 32 (inches)	24.8	14.8	0.09	13	4.1	12.8	14.2	21.2	10.2	15.8	2.8	3.7	26.9	2.7	21.4	14.6	4.7	0.79	0.47	0.71	3.94
Connector sizes									ANSI 150#				EN DIN				JIS				
DuCoNite 32									1.25"/1.5"				32mm				32mm				

Disclaimer: The information contained in this document is believed to be correct at the time of publication, but Watson-Marlow Bredel BV accepts no liability for any error it contains, and reserves the right to alter specifications without prior notice. All mentioned values in this document are values under controlled circumstances at our test bed. Actual flow rates achieved may vary because of changes in temperature, viscosity, inlet and discharge pressures and/or system configuration. APEX, DuCoNite, Bioprene and Bredel are registered trademarks.

wmfts.com/global



23 November 2023