

CIP 40

Bredel CIP hose pumps



Hose Pumps

Features and benefits

- 3A and FDA certified
- Food approved NBR pump hose, with NSF® registered food grade lubricant
- Stainless steel sanitary connectors range includes DIN, ASA or JIS
- Shoes on the rotor retract automatically for cleaning of pump element inside
- Cam actuated electrically, pneumatically or manually
- Maximum sterilization temperature 120 °C
- Bredel CIP 40 flow rates up to 4,800 L/h (42 GPM), pressures up to 16 bar (232 psi)



CIP 40 performance

Bredel CIP 40

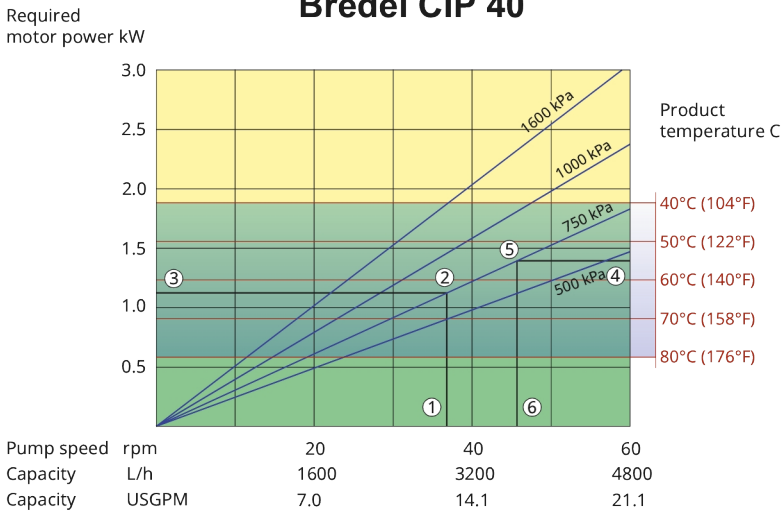

1. Flow required indicates pump speed
2. Calculated discharge pressure
3. Net motor power required
4. Product temperature
5. Calculated discharge pressure
6. Maximum recommended pump speed

- Continuous duty
- Intermittent duty

* Maximum 3 hours operation followed by minimum 1 hour stop

Technical specifications

| | CIP 40 |
|------------------------------------|--|
| Max. flow rate continuous | 4788 L/h |
| Max. flow rate continuous | 1263 USGPH |
| Max. flow rate intermittent | 4788 L/h |
| Max. flow rate intermittent | 1263 USGPH |
| Volume per revolution | 1.33 L |
| Volume per revolution | 0.35 USG |
| Max. continuous operating speed | 60 rpm |
| Max. intermittent operating speed | 60 rpm |
| Max. operating pressure | 16 bar |
| Max. operating pressure | 232 psi |
| Max. suction capability | 9.5 mWC |
| Max. suction capability | 374 inWC |
| Suction capability (80% Flow rate) | 9 mWC |
| Suction capability (80% Flow rate) | 354 inWC |
| Operating temperature range | -20 to 45 °C |
| Operating temperature range | -4 to 113 °F |
| Fluid temperature range | -20 to 80 °C |
| Fluid temperature range | -4 to 176 °F |
| Min. starting torque | 320 N m |
| Min. starting torque | 2832 in/lbs |
| Weight | 175 kg |
| Weight | 386 lbs |
| Pumphead weight | 139 kg |
| Pumphead weight | 306 lbs |
| Hose lubricant required | 10 L |
| Hose lubricant required | 2.6 USG |
| Port configurations | Down, Left, Right, Up |
| Compatible hose materials | CSM, EPDM, F-NBR, NBR, NR, NR Endurance |
| Compatible tube materials | Bioprene |
| Flange assembly type | ANSI, DIN, JIS |
| Sanitary connector options | DIN 11851, DIN 11864, IDF, RJT, SMS, Tri-clamp |

Please consult your Bredel representative for lower or higher temperature operation.

Allowable ambient temperature is based on pump capabilities and may be further limited by gearbox ambient capabilities.

Materials of construction

| | CIP 40 |
|------------------------|---|
| Hose material | Bioprene (tube), CSM, EPDM, F-NBR, Natural rubber (NR), NBR, NBR for food, NR Endurance |
| Housing | Cast iron |
| Rotor assembly | Cast iron |
| Cover assembly | Cast iron |
| Brackets and fasteners | Stainless steel 316 |
| Support frame | Galvanised steel, Stainless steel 316 |
| Hose clamps | Stainless steel 316 |
| Seals | NBR |

CIP 40 dimensions

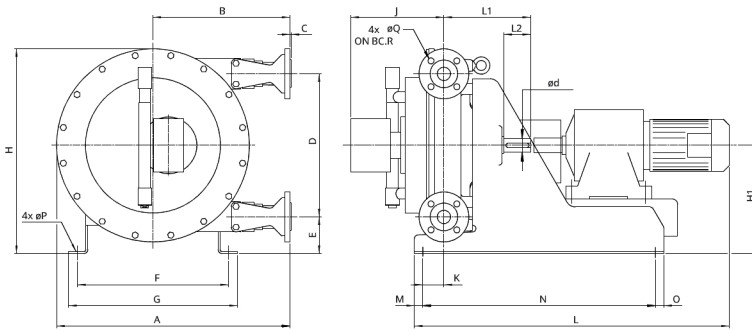

| Type | A | B | C | C | D | Ød | E | F | G | H | H1 | Jmax | K | L | L1 | L2 | M | N | O | Q | R |
|------------------------|------|------|-----|-----|------|------|-----|------|------|------|------|------|-----|---|------|-----|-----|------|-----|-----|-----|
| Bredel CIP 40 (mm) | 702 | 412 | 2.5 | 10 | 430 | 40 | 110 | 454 | 508 | 615 | 325 | 414 | 64 | * | 260 | 80 | 25 | 700 | 25 | 18 | 110 |
| Bredel CIP 40 (inches) | 27.6 | 16.2 | 0.1 | 0.4 | 16.9 | 1.57 | 4.3 | 17.9 | 20.0 | 24.2 | 12.8 | 16.3 | 2.5 | * | 10.2 | 3.1 | 1.0 | 27.6 | 1.0 | 0.7 | 4.3 |

Disclaimer: The information contained in this document is believed to be correct at the time of publication, but Watson-Marlow Bredel BV accepts no liability for any error it contains, and reserves the right to alter specifications without prior notice. All mentioned values in this document are values under controlled circumstances at our test bed. Actual flow rates achieved may vary because of changes in temperature, viscosity, inlet and discharge pressures and/or system configuration. APEX, DuCoNite, Bioprene and Bredel are registered trademarks.

wmfts.com/global



27 June 2023