

SPS 600

SPS process pump

Features and benefits

- Low shear transfer pump, with flow up to 99000 L/h at pressures up to 15 bar
- Superior viscous handling
- Consistent flow with high suction capability up to 0.85 bar
- Flexible configuration of housing, nozzle type, size orientation, drive and baseplate
- Hygienic CIP and SIP capability
- FDA and EC 1935/2004 compliance
- Operating temperatures up to 180 °C
- 20-year guarantee on front cover and pump housing



Performance curves

These performance curves show the theoretical flow without consideration of slip

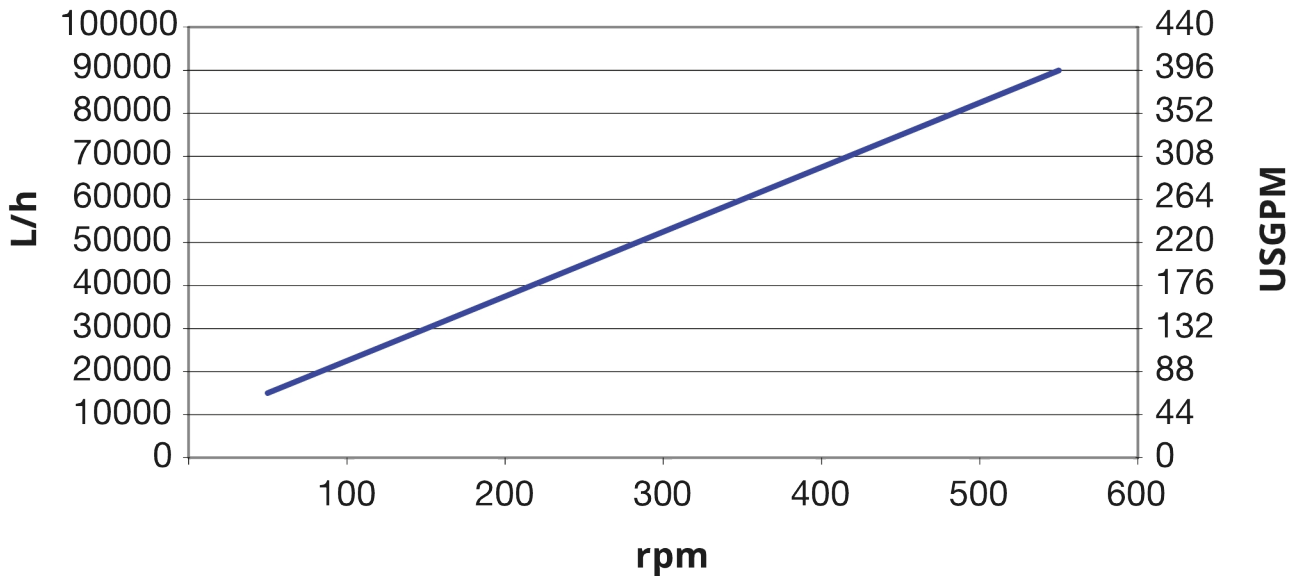

Technical specifications

	SPS 600
Max. flow rate	99000 L/h
Max. flow rate	434.2 usgpm
Volume per revolution	2.75 L
Volume per revolution	0.724 usg
Max. particle size	60 mm
Max. particle size	2.36 in
Suction pressure	85% of a vacuum
Max. operating speed	600 rpm
Max. operating pressure	15 bar
Max. operating pressure	217 psi
Operating temperature range	-20 to 180 °C
Operating temperature range	-4 to 356 °F
Standards	ATEX
Certification	EC 1935/2004, FDA
Port orientation	Various options to meet your requirements
Port type	Flange, Milk fitting, RJT, SMS, TC
Shaft diameter	65 mm
Shaft Diameter	2.56 inch
Shaft Height	9.25 inch
Shaft Height	235 mm

Materials of construction

	SPS 600
Housing	Stainless steel 1.4404, Stainless steel 316L
Bearing frame	Stainless steel 1.4301, Stainless steel 304
Rotor	Stainless steel 1.4404, Stainless steel 316L
Gate and liners	Polyamide
Seals/gaskets	EPDM, FFKM, FKM, NBR, PTFE

SPS 600 dimensions

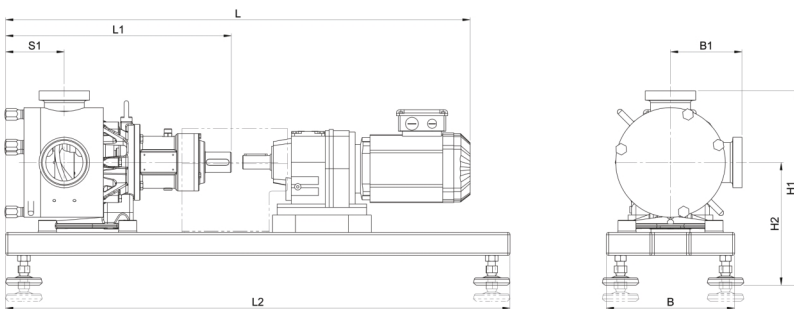

Model	L				L1		L2		S1		B		B1				H1				H2			
	min.		max.										min.		max.		min.		max.		min.		max.	
	mm	inch	mm	inch	mm	inch	mm	inch	mm	inch	mm	inch	mm	inch	mm	inch	mm	inch	mm	inch	mm	inch	mm	inch
SPS 600	1755	69.1	2200	86.6	771	30.4	1400	55.1	319	12.6	400	15.8	274	10.8	274	10.8	630	24.8	700	27.6	353	13.9	433	17.1

Disclaimer: All flow rates shown were obtained pumping water at 20 °C (68 °F) with zero suction and delivery heads. Disclaimer: The information contained in this document is believed to be correct but Watson-Marlow Limited accepts no liability for any errors it contains and reserves the right to alter specifications without notice. Watson-Marlow, MasoSine, Qdos, ReNu, LoadSure, Bioprene, Pumpsil and Marprene are trademarks of Watson-Marlow Limited. STA-PURE PFL® and STA-PURE PCS® are registered trademarks of W.L Gore & Associates Inc. Please state the product code when ordering pumps and tubing.

wmfts.com/global



31 May 2023