

Certa Plus 100

Certa Plus process pump

Features and benefits

- Gentle product handling preserves high quality of product
- Impressive suction capability
- Almost zero pulsation
- Outstanding energy efficient pumping principle
- Bi-directional running
- Only one shaft and one seal system
- Different port orientations available, including self-draining position
- Traceability back to base materials



Performance curves

These performance curves show the theoretical flow without consideration of slip

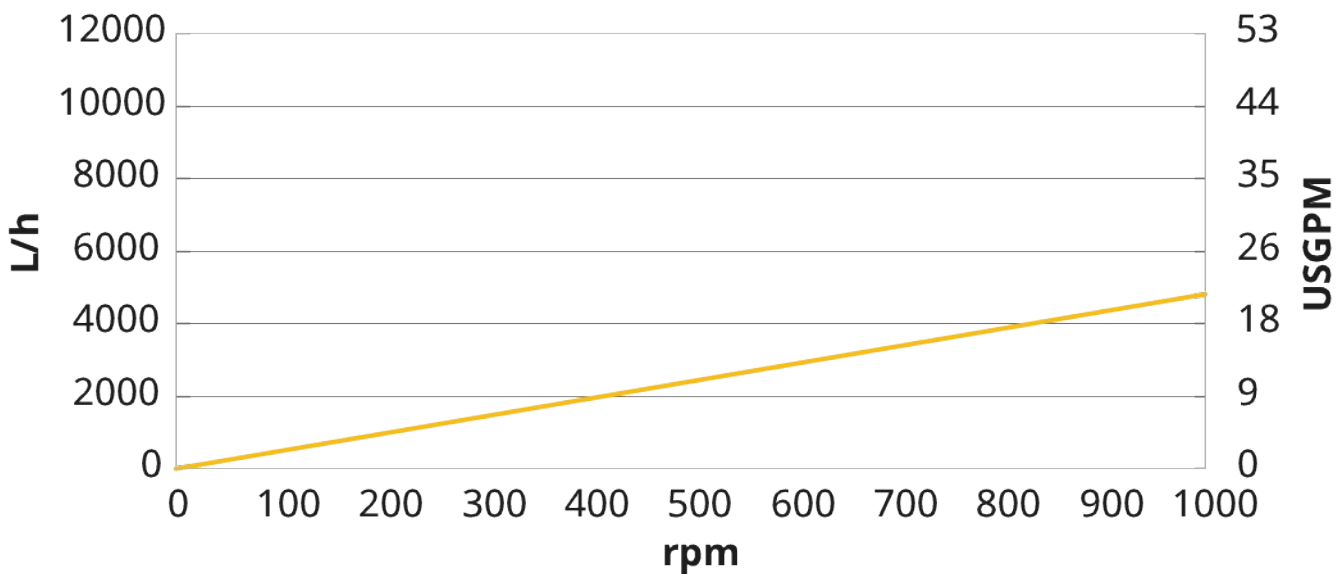

Technical specifications

	Certa Plus 100
Max. flow rate	4800 L/h
Max. flow rate	21.1 usgpm
Volume per revolution	0.08 L
Volume per revolution	0.021 usg
Max. particle size	13 mm
Max. particle size	0.51 in
Suction pressure	85% of a vacuum
Max. operating speed	1000 rpm
Max. operating pressure	6 bar
Max. operating pressure	87 psi
Operating temperature range	-20 to 100 °C
Operating temperature range	-4 to 212 °F
Max. SIP temperature	121 °C
Max. SIP temperature	250 °F
Shaft diameter	28 mm
Shaft diameter	0.98 inch
Shaft height	95 mm
Shaft height	3.74 inch
Standards	3-A, ATEX, EHEDG Type EI Class I, EHEDG Type EL Class I Aseptic
Certification	EC 1935/2004, FDA, USP ClassVI
Port orientation	Various options to meet your requirements
Port type	Flange, Milk fitting, RJT, SMS, TC

Materials of construction

	Certa Plus 100
Housing	Stainless steel 1.4435, Stainless steel 316L
Bearing frame	Stainless steel 1.4301, Stainless steel 304
Rotor	Stainless steel 1.4435, Stainless steel 316L
Gate	PEEK, PTFE
Seals/gaskets	EPDM, FKM
Shaft seal	PTFE, SSIC

Certa Plus 100 dimensions

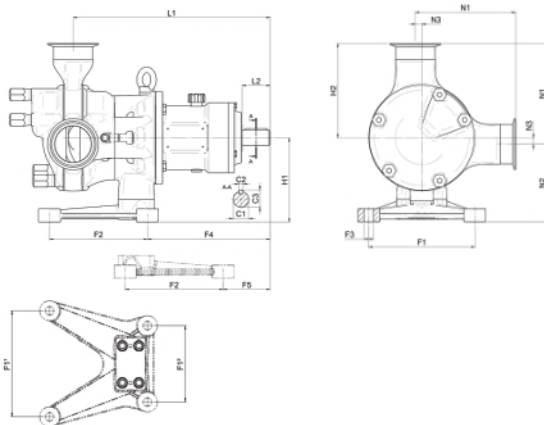

Model	Nozzles						Foot								Length				Height				Coupling							
	N1		N2		N3		F1		F2		F3		F4		F5		L1		L2		H1		H2		C1		C2		C3	
	mm	in.	mm	in.	mm	in.	mm	in.	mm	in.	mm	in.	mm	in.	mm	in.	mm	in.	mm	in.	mm	in.	mm	in.	mm	in.	mm	in.	mm	in.
C100	139	5.47	85	3.35	10	0.39	120	4.72	135	5.31	Ø12	Ø0.47	143	5.63	57	2.24	265	10.43	50	1.97	95	3.74	129	5.08	Ø28	Ø1.10	8	0.31	31	1.22

Disclaimer: All flow rates shown were obtained pumping water at 20 °C (68 °F) with zero suction and delivery heads. Disclaimer: The information contained in this document is believed to be correct but Watson-Marlow Limited accepts no liability for any errors it contains and reserves the right to alter specifications without notice. Watson-Marlow, MasoSine, Qdos, ReNu, LoadSure, Bioprene, Pumpsil and Marprene are trademarks of Watson-Marlow Limited. STA-PURE PFL® and STA-PURE PCS® are registered trademarks of W.L Gore & Associates Inc. Please state the product code when ordering pumps and tubing.

wmfts.com/global



Thursday, May 11, 2023